

CONSULTANTS **€**UROPE bv
TECHNICAL & LEGAL EXPERTS

DESIGN EVALUATION REPORT

**FOR THE
Cable Management System**



Assured Protection Vista A.P.V
Damascus, Daara Old St. Al bardch exit
P.O. Box: sbenh 76
Syria

CERTIFICATE **TÜV NORD**

Management system as per
EN ISO 9001 : 2000

In accordance with TÜV NORD CERT procedures, it is hereby certified that

**ASSURED PROTECTION VISTA
A.P.V For Cables Management Systems**

P.O. Box: Sbeneh 76,
Daraa Old St.,
Damascus, Syria



applies a management system in line with the above standard for the following scope

Manufacturing of cables management systems; Solid systems, trunking systems, perforated systems, ladder-type systems, flexible system.

Certificate Registration No. 44 100 081568
Audit Report No. 3503 6924

Valid until 2011-09-25

G. Bräutigam
Certification Body
at TÜV NORD CERT GmbH

Essen, 2008-09-26

This certification was conducted in accordance with the TÜV NORD CERT auditing and certification procedures and is subject to regular surveillance audits.

TÜV NORD CERT GmbH

Langemarckstrasse 20

45141 Essen

www.tuev-nord-cert.com



TGA-ZM-07-06-00

EC DECLARATION OF CONFORMITY

NR: 030709/APV/01

PRODUCT DESCRIPTION

Product name : Solid Cable Tray "Trunking" SCT.

MANUFACTURER

Company : APV for Cables Management Systems
Address : Daraa old ST. Al bardeh Exit
Zipcode and place : Damascus
Country : Syria
Authorised : Mhd. Mazen Al Malat
Position : General Manager

INVESTIGATED BY

Company : Consultants Europe bv
Address : Nieuwstraat 60
Zipcode and place : 1381 BD Weesp
Country : The Netherlands



HARMONISATION

This product complies with the Safety regulations of the

Construction Products Directive 89/106/EC
Low Voltage Directive 2006/95/EC

and amongst others the following harmonized standards

NEN-EN-IEC 61537 NEN-EN 10025-5
NEN-EN-ISO 1461 NEN-EN 50085-1
NEN-EN 50085-2-1

Place:

Date:

Signature Manufacturer:

The findings in this report refer only to the sample submitted and do not guarantee the bulk of the items from which the sample was obtained to be of equal quality.

EC DECLARATION OF CONFORMITY

NR: 030709/APV/02

PRODUCT DESCRIPTION

Product name : Perforated Cable Tray PCT.

MANUFACTURER

Company : APV for Cables Management Systems
Address : Daraa old ST. Al bardeh Exit
Zipcode and place : Damascus
Country : Syria
Authorised : Mhd. Mazen Al Malat
Position : General Manager

INVESTIGATED BY

Company : Consultants Europe bv
Address : Nieuwstraat 60
Zipcode and place : 1381 BD Weesp
Country : The Netherlands



HARMONISATION

This product complies with the Safety regulations of the

Construction Products Directive 89/106/EC
Low Voltage Directive 2006/95/EC

and amongst others the following harmonized standards

NEN-EN-IEC 61537 NEN-EN 10025-5
NEN-EN-ISO 1461 NEN-EN 50085-1
NEN-EN 50085-2-1

Place:

Date:

Signature Manufacturer:

The findings in this report refer only to the sample submitted and do not guarantee the bulk of the items from which the sample was obtained to be of equal quality.

EC DECLARATION OF CONFORMITY

NR: 030709/APV/07

PRODUCT DESCRIPTION

Product name : Cable Ladder Cover CLC.

MANUFACTURER

Company : APV for Cables Management Systems
Address : Daraa old ST. Al bardeh Exit
Zipcode and place : Damascus
Country : Syria
Authorised : Mhd. Mazen Al Malat
Position : General Manager

INVESTIGATED BY

Company : Consultants Europe bv
Address : Nieuwstraat 60
Zipcode and place : 1381 BD Weesp
Country : The Netherlands



HARMONISATION

This product complies with the Safety regulations of the

Construction Products Directive 89/106/EC
Low Voltage Directive 2006/95/EC

and amongst others the following harmonized standards

NEN-EN-IEC 61537 NEN-EN 10025-5
NEN-EN-ISO 1461 NEN-EN 50085-1
NEN-EN 50085-2-1

Place:

Date:

Signature Manufacturer:

The findings in this report refer only to the sample submitted and do not guarantee the bulk of the items from which the sample was obtained to be of equal quality.

EC DECLARATION OF CONFORMITY

NR: 030709/APV/03

PRODUCT DESCRIPTION

Product name : Cable Tray Cover CTC.

MANUFACTURER

Company : APV for Cables Management Systems
Address : Daraa old ST. Al bardeh Exit
Zipcode and place : Damascus
Country : Syria
Authorised : Mhd. Mazen Al Malat
Position : General Manager

INVESTIGATED BY

Company : Consultants Europe bv
Address : Nieuwstraat 60
Zipcode and place : 1381 BD Weesp
Country : The Netherlands



HARMONISATION

This product complies with the Safety regulations of the

Construction Products Directive 89/106/EC
Low Voltage Directive 2006/95/EC

and amongst others the following harmonized standards

NEN-EN-IEC 61537 NEN-EN 10025-5
NEN-EN-ISO 1461 NEN-EN 50085-1
NEN-EN 50085-2-1

Place:

Date:

Signature Manufacturer:

The findings in this report refer only to the sample submitted and do not guarantee the bulk of the items from which the sample was obtained to be of equal quality.

EC DECLARATION OF CONFORMITY

NR: 030709/APV/06

PRODUCT DESCRIPTION

Product name : Heavy Cable Ladder HCL.

MANUFACTURER

Company : APV for Cables Management Systems
Address : Daraa old ST. Al bardeh Exit
Zipcode and place : Damascus
Country : Syria
Authorised : Mhd. Mazen Al Malat
Position : General Manager

INVESTIGATED BY

Company : Consultants Europe bv
Address : Nieuwstraat 60
Zipcode and place : 1381 BD Weesp
Country : The Netherlands



HARMONISATION

This product complies with the Safety regulations of the

Construction Products Directive 89/106/EC
Low Voltage Directive 2006/95/EC

and amongst others the following harmonized standards

NEN-EN-IEC 61537 NEN-EN 10025-5
NEN-EN-ISO 1461 NEN-EN 50085-1
NEN-EN 50085-2-1

Place:

Date:

Signature Manufacturer:

The findings in this report refer only to the sample submitted and do not guarantee the bulk of the items from which the sample was obtained to be of equal quality.

EC DECLARATION OF CONFORMITY

NR: 030709/APV/04

PRODUCT DESCRIPTION

Product name : Light Cable Ladder LCL.

MANUFACTURER

Company : APV for Cables Management Systems
Address : Daraa old ST. Al bardeh Exit
Zipcode and place : Damascus
Country : Syria
Authorised : Mhd. Mazen Al Malat
Position : General Manager

INVESTIGATED BY

Company : Consultants Europe bv
Address : Nieuwstraat 60
Zipcode and place : 1381 BD Weesp
Country : The Netherlands



HARMONISATION

This product complies with the Safety regulations of the

Construction Products Directive 89/106/EC
Low Voltage Directive 2006/95/EC

and amongst others the following harmonized standards

NEN-EN-IEC 61537 NEN-EN 10025-5
NEN-EN-ISO 1461 NEN-EN 50085-1
NEN-EN 50085-2-1

Place:

Date:

Signature Manufacturer:

The findings in this report refer only to the sample submitted and do not guarantee the bulk of the items from which the sample was obtained to be of equal quality.

EC DECLARATION OF CONFORMITY

NR: 030709/APV/05

PRODUCT DESCRIPTION

Product name : Medium Cable Ladder MCL.

MANUFACTURER

Company : APV for Cables Management Systems
Address : Daraa old ST. Al bardeh Exit
Zipcode and place : Damascus
Country : Syria
Authorised : Mhd. Mazen Al Malat
Position : General Manager

INVESTIGATED BY

Company : Consultants Europe bv
Address : Nieuwstraat 60
Zipcode and place : 1381 BD Weesp
Country : The Netherlands



HARMONISATION

This product complies with the Safety regulations of the

Construction Products Directive 89/106/EC
Low Voltage Directive 2006/95/EC

and amongst others the following harmonized standards

NEN-EN-IEC 61537 NEN-EN 10025-5
NEN-EN-ISO 1461 NEN-EN 50085-1
NEN-EN 50085-2-1

Place:

Date:

Signature Manufacturer:

The findings in this report refer only to the sample submitted and do not guarantee the bulk of the items from which the sample was obtained to be of equal quality.



APV Cables Management Systems
P.O. Box: Sbenh 76
Daara Old St. Albardeh
DAMASCUS

Syria

Your ref. H.D.G. test perforated cable tray
Our ref. 71100516-PGR/NET
11-5099 Zui/GvW
Tel. +31 26 3 56 33 83
Fax +31 26 4 45 46 59
E-mail henk.vanzuilen@kema.com

Arnhem, May 16, 2011

**Subject: Hot deep galvanizing test on a perforated cable tray according the standards
ASTM A90/A 90M – 01 and EN ISO 1461:1999**

Whom It may concern,

Enclosed you receive the results of the hot deep galvanizing test on the delivered perforated cable tray with a length of 1000 mm, a height of 50 mm and a width of 400 mm. The thickness of the cable tray was 1.5 mm. The delivered perforated cable tray has been galvanized by ELTEL MIDDLE EAST. The hot deep galvanizing tests were performed in accordance with the standards ASTM A90/A 90M – 01 and EN ISO 1461:1999 (TIC order number 70022904).

Table 1 The results of the determination of the mass of zinc per area by the gravimetric method

sample number	surface area sample mm ²	zinc content mass in g/m ²
1	8892	399
2	11750	381
3	8058	381
average		387
stdev		10

As the standard ASTM A90/A 90M – 01 only describes the procedures for determining the weight (mass) of coating on iron or steel sheet no minimum values of the mass of zinc are mentioned in this standard.

The standard EN ISO 1461:1999 Annex D.1 states that for steel with a maximum thickness of 1.5 mm the local coating should be 250 g/m² while the mean coating should be at least 325 g/m². The measured values in the test of the three samples comply with the standard.

Conclusion

The measured values of zinc on the delivered cable tray comply with the standard ASTM A90/A 90M – 01 and the standard EN ISO 1461:1999 Annex D.1.

Sincerely yours,

KEMA Nederland B.V.

A handwritten signature in blue ink, appearing to be "H.G. van Zuilen". The signature is stylized and somewhat abstract, with several loops and a long horizontal stroke at the end.

H.G. van Zuilen

KEMA Power Generation and Renewables



شهادة اعتماد

إعتماد كيبيل تري A.PV

اسم الشركة / المصنع :

شركة بريميوم للتجارة العامة والمقاولات

العنوان :

شارع سالم المبارك - مجمع بوخمسين

بنوك (٢٠) مبنى (٣٦) الدور (٣) مكتب (١٤)

ت: - ٢٥٧٣١٦٨٠

تاريخ الإنهاء :

2011 / 8 / 2

تاريخ الإصدار :

2009 / 8 / 3

وصف المواد المعتمدة :

إعتماد كيبيل تري A.PV

ملاحظات :

1. ضرورة الالتزام بالموصفات العامة للوزارة و المواصفات الخاصة لكل مشروع على حده والمتعلقة بهذا المنتج .
2. يتم التقدم بهذا المنتج من خلال المقاولين المعتمدين لمشاريع وزارة الأشغال العامة التي يطلب فيها استخدام هذا المنتج شريطة أن يطابق مواصفات هذا المنتج المواصفات الخاصة لأي عقد من عقود وزارة الأشغال العامة كل على حدة .
3. تتلزم وزارة الأشغال العامة بتطبيق القرار الوزاري رقم (6) لعام 1987 و القرار المعدل له رقم (282) لعام 2000 و الخاص بمنح الأولوية في المشتريات الحكومية للمنتجات الوطنية و ذات المنشأ الوطني .
4. هذا الاعتماد لا يعطى هذا المنتج من اجراء الفحوصات اللازمة عند التوريد لأي مشروع .
5. في حالة تغيير بلد المنشأ للمنتج (سوريا) يعتبر هذا الاعتماد لاغى .

المهندس / وكيل وزارة الأشغال العامة
علي المعيوف
رئيس مهند المركز الحكومي
لفحوصات خط الأنابيب





ISO 9001:2000
Reg. 7977-1

SANS PREJUDICE

Place and date : Weesp, 16 February, 2010

Compiled by : D. Rubio Borrajo

Investigated by : S. Koumatchev

Verified by : Mr. R. Glaser Eng & LL.M.
Technical and Legal Expert

By request of : MHD.Mazen Al Malat
General Manager

Company : Assured Protection Vista (A.P.V.)
PO Box: Sbeneh76
Damascus - Syria

Subject : Design evaluation report for cable management system

Reference number : 230210/APV/01

Number of pages : 78

Number of appendices : 6

Task Date : February 2010



ISO 9001:2000
Reg. 7977-1

Summary:

A design review of the Cable Tray Systems designs were evaluated by Consultants Europe BV to determine if the products comply with the essential requirements out of the National Electrical Code (NEC) of the United States of America and the Canadian Electrical Code (CEC) of Canada.

The Cable Tray Systems were investigated, verified and concluded that the investigated samples are not in compliance with the essential requirements of the National Electrical Code and Canadian Electrical Code according to the following relevant guidelines and regulations;

1. National Electrical Code and Canadian Electrical Code
2. OSHA 29 CFR 1910.305
3. NEMA VE1 – Metal Cable Tray Systems
4. NEMA VE2 – Metal Cable Tray Installation Guidelines

To assure compliance with the essential requirements of the National Electrical Code and Canadian Electrical Code Consultants Europe BV has summed up a few recommendations that can be found in the conclusion of this report.

This design evaluation report is based on the samples and documentation delivered to Consultants Europe BV. Consultants Europe BV cannot be held responsible if the production is not of the same quality or composition as the delivered samples. Consultants Europe cannot be held responsible or liable if any incorrect samples or information have been delivered.



TABLE OF CONTENTS

1. INTRODUCTION	5
1.1 Description of the investigation.....	5
1.2 Name of the products.....	5
1.3 Standards and Guidelines	6
2. DESIGN INSPECTION REPORT.....	8
3. TEST REPORTS	36
3.1 Test Description.....	36
3.2 Test Results.....	36
3.3 Zinc Layer Thickness	38
4. CONCLUSION AND RECOMMENDATIONS.....	41
Annex A – Drawings (main components).....	44
Annex B – Drawings (supporting system)	56
Annex C – Design Instructions	57
Annex D – Contact Information.....	60
Annex E – General Product and Manufacturer Information	61
Annex F – Component dimensions	73
Annex G – NEMA VE 1-2009.....	
Annex H – NEMA VE 2-2000.....	

Consultants Europe B.V. can not be held responsible for changes or modifications in the documentation delivered by Assured Protection Vista. These documents are attached in the annexes in this report.



1. INTRODUCTION

1.1 *Description of the investigation*

The technical and legal company "Consultants Europe BV" has been assigned by Assured Protection Vista in Syria to carry out a design investigation for the Cable Management System in compliance with the product samples and information which has been received. The design investigation has been based on the essential requirements out of the regulations and guidelines of the United States of America and Canada.

The investigation only relates to the samples received. Consultants Europe BV cannot guarantee that the production will be of the same quality as the samples.

TUV ISO 9001-2000

Consultants Europe investigation and certification procedures are in compliance with a TUV ISO 9001-2000 quality management system.

1.2 *Name of the products*

The following products are taken into account (see Annex A);

- Solid Cable Tray "Trunking" SCT
- Perforated Cable Tray PCT
- Cable Tray Cover CTC
- Light Cable Ladder LCL
- Medium Cable Ladder MCL
- Heavy Cable Ladder HCL
- Cable Ladder Cover CLC



1.3 *Standards and guidelines*

The products as mentioned under section 1.2 shall comply with the following regulations and guidelines;

1.3.1 *Regulations*

The following regulations apply to the products as mentioned under section 1.2;

1. OSHA 29 CFR 1910.305 (a)(3)

Scope: Wiring methods, components, and equipment for general use **by the** Occupational Safety and Health Standards

2. National Electrical Code (NEC), NFPA 70, Articles 250, 392 and 800

Scope: This Code covers the installation of electrical conductors, equipment, and raceways; signaling and communications conductors, equipment, and raceways; and optical fiber cables and raceways for the following:

- Public and private premises, including buildings, structures, mobile homes, recreational vehicles, and floating buildings;
- Yards, lots, parking lots, carnivals, and industrial substations;
- Installations of conductors and equipment that connect to the supply of electricity;
- Installations used by the electric utility, such as office buildings, warehouses, garages, machine shops, and recreational buildings, that are not an integral part of a generating plant, substation, or control center.

FPN: Although the scope of this Code indicates that the Code does not cover installations in ships, portions of this Code are incorporated by reference into Title 46, Code of Federal Regulations, Parts 110–113.

- Installations underground in mines and self-propelled mobile surface mining machinery and its attendant electrical trailing cable
- Installations of railways for generation, transformation, transmission, or distribution of power used exclusively for operation of rolling stock or installations used exclusively for signaling and communications purposes
- Installations of communications equipment under the exclusive control of communications utilities located outdoors or in building spaces used exclusively for such installations under the exclusive control of an electric utility where such installations:

- a. Consist of service drops or service laterals, and associated metering, or
- b. Are located in legally established easements or rights-of-way designated by or recognized by public service commissions, utility commissions, or other regulatory agencies having jurisdiction for such installations, or
- c. Are on property owned or leased by the electric utility for the purpose of communications, metering, generation, control, transformation, transmission, or distribution of electric energy. FPN to (4) and (5): Examples of utilities may include those entities that are typically designated or recognized by governmental law or regulation by public service/utility commissions and that install, operate, and maintain electric supply (such as generation, transmission, or distribution systems) or communication systems (such as telephone, CATV, Internet, satellite, or data services).

Utilities may be subject to compliance with codes and standards covering their regulated activities as adopted under governmental law or regulation. Additional information can be found through consultation with the appropriate governmental bodies, such as state regulatory commissions, the Federal Energy Regulatory Commission, and the Federal Communications Commission. (C) Special Permission.

The authority having jurisdiction for enforcing this Code may grant exception for the installation of conductors and equipment that are not under the exclusive control of the electric utilities and are used to connect the electric utility supply system to the service-entrance conductors of the premises served, provided such installations are outside a building or terminate immediately inside a building wall.

3. Individual states may also impose additional regulations

1.3.2 *References and guidelines*

The following standards have to be in compliance with the products as mentioned under section 1.2;

1. NEMA VE1 – Metal Cable Tray Systems.

Scope: this standard specifies the requirements for metal cable trays and associated fittings designed for use in accordance with the rules of the Canadian Electrical Code (CEC), Part I, and the National Electrical Code of the United States of America (NEC). This standard is not mandatory but it provides guidance for metal cable trays for use in accordance with the NEC.

2. NEMA VE2 – Metal Cable Tray Installation Guidelines.

Scope: this publication addresses shipping, and installing cable tray systems. Information on maintenance and system modification is also provided. This standard is not mandatory but it addresses cable installation guidelines covering receiving and unloading material, storage and general installation practices



ISO 9001:2000
Reg. 7977-1

2. DESIGN EVALUATION REPORT

All information in this Design Evaluation Rapport or resulting from work as depicted in this Design Evaluation Rapport are exclusively intended only for Assured Protection Vista and Consultants Europe BV, and cannot be given or transferred to third parties without official written permission from Consultants Europe BV conforming to the General conditions of Consultants Europe BV. To ensure protection of our client's information, documentation or products sent to Consultants Europe BV we guarantee full confidentiality. This design evaluation rapport is based on the samples and information delivered to Consultants Europe BV. Consultants Europe BV cannot be held responsible if the production is not of the same quality or composition as the delivered samples. Consultants Europe BV cannot be held responsible if the samples delivered are damaged during testing or transport. Our General Conditions are effective to all our offers and services, as deposited at the Chamber of Commerce in Hilversum, number 321 010 61. You can receive a free copy on request.

The company Assured Protection Vista needs to follow up the assessments indicated in bold and italic. The indicated provisions need to be supported with digital photograph, relevant documentation, the required information needs to be made available to the Technical and Legal Department as soon as possible.

Address: Assured Protection Vista A.P.V Damascus, Daara Old St. Al bardeh exit P.O. Box: sbenh 76 Syria	Client name: MHD.Mazen Al Malat <i>General Manager</i>	Object: Cable Management System
Contact(s) at Consultants Europe: S. Koumatchev	Report number: 230210/APV/01	Date: February 23, 2010
Evaluation performed by: Mr. David Rubio Borrajo	Within the framework of: 1. OSHA 29 CFR 1910.305 2. National Electrical Code and Canadian Electrical Code 3. NEMA VE1 – Metal Cable Tray Systems 4. NEMA VE2 – Metal Cable Tray Installation Guidelines	Location: Consultants Europe Nieuwstad 100 1381 CE Weesp The Netherlands
Requirements	In conformity with the Directive(s)	Assessment
1) The complete product should be solid and undamaged	National Electrical Code and; Canadian Electrical Code	The Cable Management System is visible solid and undamaged. Checked by Consultants Europe



ISO 9001:2000
Reg. 7977-1

CONSULTANTS EUROPE bv

TECHNICAL & LEGAL EXPERTS

Address: Assured Protection Vista A.P.V Damascus, Daara Old St. Al bardeh exit P.O. Box: sbenh 76 Syria	Client name: MHD.Mazen Al Malat <i>General Manager</i>	Object: Cable Management System
Contact(s) at Consultants Europe: S. Koumatchev	Report number: 230210/APV/01	Date: February 23, 2010
Evaluation performed by: Mr. David Rubio Borrajo	Within the framework of: 1. OSHA 29 CFR 1910.305 2. National Electrical Code and Canadian Electrical Code 3. NEMA VE1 – Metal Cable Tray Systems 4. NEMA VE2 – Metal Cable Tray Installation Guidelines	Location: Consultants Europe Nieuwstad 100 1381 CE Weesp The Netherlands
Requirements	In conformity with the Directive(s)	Assessment
2) The construction of a product should be solid and undamaged.	National Electrical Code and; Canadian Electrical Code	The construction of the Cable Management System is solid and undamaged. Checked by Consultants Europe
3) The essential components of a product should be sufficiently strong and durable	National Electrical Code and; Canadian Electrical Code	The essential components of the Cable Management System are sufficient strong and durable. Checked by Consultants Europe
4) The stability of a product should meet the requirements of the National Electrical Code and the Canadian Electrical Code	National Electrical Code and; Canadian Electrical Code	The stability of the Cable Management System meets the requirements of the National Electrical Code and Canadian Electrical Code Checked by Consultants Europe



ISO 9001:2000
Reg. 7977-1

Address: Assured Protection Vista A.P.V Damascus, Daara Old St. Al bardeh exit P.O. Box: sbenh 76 Syria	Client name: MHD.Mazen Al Malat <i>General Manager</i>	Object: Cable Management System
Contact(s) at Consultants Europe: S. Koumatchev	Report number: 230210/APV/01	Date: February 23, 2010
Evaluation performed by: Mr. David Rubio Borrajo	Within the framework of: 1. OSHA 29 CFR 1910.305 2. National Electrical Code and Canadian Electrical Code 3. NEMA VE1 – Metal Cable Tray Systems 4. NEMA VE2 – Metal Cable Tray Installation Guidelines	Location: Consultants Europe Nieuwstad 100 1381 CE Weesp The Netherlands
Requirements	In conformity with the Directive(s)	Assessment
5) The essential components of a product should be sufficiently flexible.	National Electrical Code and; Canadian Electrical Code	The essential components of the Cable Management System are sufficient flexible. Checked by Consultants Europe
6) The finishing of a product should be visibly in a good state. Damages may not cause design risks	National Electrical Code and; Canadian Electrical Code	The finishing of the Cable Management System is in a correct state and there were no damages which could cause design risks noticeable. Checked by Consultants Europe
7) Materials used for the construction of the product or products used and created by its usage may not cause any hazard for the design or health of the persons exposed	National Electrical Code and; Canadian Electrical Code	The materials used for the construction of the Cable Management System cannot cause any hazard for the design or health of the persons exposed. Checked by Consultants Europe



ISO 9001:2000
Reg. 7977-1

CONSULTANTS EUROPE bv

TECHNICAL & LEGAL EXPERTS

Address: Assured Protection Vista A.P.V Damascus, Daara Old St. Al bardeh exit P.O. Box: sbenh 76 Syria	Client name: MHD.Mazen Al Malat <i>General Manager</i>	Object: Cable Management System
Contact(s) at Consultants Europe: S. Koumatchev	Report number: 230210/APV/01	Date: February 23, 2010
Evaluation performed by: Mr. David Rubio Borrajo	Within the framework of: 1. OSHA 29 CFR 1910.305 2. National Electrical Code and Canadian Electrical Code 3. NEMA VE1 – Metal Cable Tray Systems 4. NEMA VE2 – Metal Cable Tray Installation Guidelines	Location: Consultants Europe Nieuwstad 100 1381 CE Weesp The Netherlands
Requirements	In conformity with the Directive(s)	Assessment
8) A product should meet the requirements of the required standard	National Electrical Code and; Canadian Electrical Code and; NEMA VE 1-2009 and; NEMA VE 2-2000	The Cable Management System is in accordance with all relevant articles of the required standard. Checked by Consultants Europe
9) Cable trays shall have suitable strength and rigidity to support the intended wiring.	National Electrical Code and; Canadian Electrical Code and; NEMA VE 1-2009 and; NEMA VE 2-2000	<i>The marketing literature includes a case study of strength calculation (resistance to bending) for a cable tray section. Cable tray strengths, loading and proper support are not addressed in the design instructions. This must be modified (see recommendations in conclusion of this report) and send back to Consultants Europe for verification.</i> Checked by Consultants Europe



ISO 9001:2000
Reg. 7977-1

CONSULTANTS EUROPE bv

TECHNICAL & LEGAL EXPERTS

Address: Assured Protection Vista A.P.V Damascus, Daara Old St. Al bardeh exit P.O. Box: sbenh 76 Syria	Client name: MHD.Mazen Al Malat <i>General Manager</i>	Object: Cable Management System
Contact(s) at Consultants Europe: S. Koumatchev	Report number: 230210/APV/01	Date: February 23, 2010
Evaluation performed by: Mr. David Rubio Borrajo	Within the framework of: 1. OSHA 29 CFR 1910.305 2. National Electrical Code and Canadian Electrical Code 3. NEMA VE1 – Metal Cable Tray Systems 4. NEMA VE2 – Metal Cable Tray Installation Guidelines	Location: Consultants Europe Nieuwstad 100 1381 CE Weesp The Netherlands
Requirements	In conformity with the Directive(s)	Assessment
10) Edges and corners of a product should be correctly trimmed	National Electrical Code and; Canadian Electrical Code	The edges and corners of the Cable Management System are evaluated and there are no visible imperfections established. Checked by Consultants Europe
11) A product should work without any noticeable problem(s)	National Electrical Code and; Canadian Electrical Code	The working of the Cable Management System has been established. Checked by Consultants Europe
12) A product should function without any noticeable problem(s)	National Electrical Code and; Canadian Electrical Code	We have established the Cable Management System functions without problems. Checked by Consultants Europe



ISO 9001:2000
Reg. 7977-1

CONSULTANTS EUROPE bv

TECHNICAL & LEGAL EXPERTS

Address: Assured Protection Vista A.P.V Damascus, Daara Old St. Al bardeh exit P.O. Box: sbenh 76 Syria	Client name: MHD.Mazen Al Malat <i>General Manager</i>	Object: Cable Management System
Contact(s) at Consultants Europe: S. Koumatchev	Report number: 230210/APV/01	Date: February 23, 2010
Evaluation performed by: Mr. David Rubio Borrajo	Within the framework of: 1. OSHA 29 CFR 1910.305 2. National Electrical Code and Canadian Electrical Code 3. NEMA VE1 – Metal Cable Tray Systems 4. NEMA VE2 – Metal Cable Tray Installation Guidelines	Location: Consultants Europe Nieuwstad 100 1381 CE Weesp The Netherlands
Requirements	In conformity with the Directive(s)	Assessment
13) Cable trays and their fittings are to be identified for the intended use. Allowed uses in accordance with support system for service conductors, feeders, branch circuits, communications circuits, control circuits, and signaling circuits. Only the wiring methods noted in Table 392.3 can be used with cable trays.	National Electrical Code Table 392.3 and; Canadian Electrical Code and; OSHA 29 CFR 1910.305	<i>The design instructions and marketing literature reviewed do not address intended use. This must be modified (see recommendations in conclusion of this report) and send back to Consultants Europe for verification. Checked by Consultants Europe</i>
14) In the production of the product, precaution measures must be taken in order to prevent falling or flying out of objects, which may cause a hazard, such in conformity with the essential requirements of the National Electrical Code and Canadian Electrical Code	National Electrical Code and; Canadian Electrical Code	Precautions measures have been taken at the Cable Management System to prevent objects from falling or flying off, which may cause a hazard. Checked by Consultants Europe

Address: Assured Protection Vista A.P.V Damascus, Daara Old St. Al bardeh exit P.O. Box: sbenh 76 Syria	Client name: MHD.Mazen Al Malat <i>General Manager</i>	Object: Cable Management System
Contact(s) at Consultants Europe: S. Koumatchev	Report number: 230210/APV/01	Date: February 23, 2010
Evaluation performed by: Mr. David Rubio Borrajo	Within the framework of: 1. OSHA 29 CFR 1910.305 2. National Electrical Code and Canadian Electrical Code 3. NEMA VE1 – Metal Cable Tray Systems 4. NEMA VE2 – Metal Cable Tray Installation Guidelines	Location: Consultants Europe Nieuwstad 100 1381 CE Weesp The Netherlands
Requirements	In conformity with the Directive(s)	Assessment
15) All metallic cable tray systems are to be bonded and grounded (protectively earthed). A steel or aluminum cable tray system can serve as the equipment grounding (earthing) conductor means under the conditions named in the National Electrical and Candian Electrical Code.	National Electrical Code articles 250 and 392.7 and; Canadian Electrical Code	<i>The design instructions and marketing literature do not address appropriate grounding and bonding means or whether the cable tray systems are intended for use as equipment grounding conductors. This must be modified (see recommendations in conclusion of this report) and send back to Consultants Europe for verification. Checked by Consultants Europe</i>
16) Parts of a product, which form any hazard, must be designed so that the users health will not be affected	National Electrical Code and; Canadian Electrical Code	There are no parts of the Cable Management System which form any hazard to the user's health in normal use. Checked by Consultants Europe
17) A product must be designed and constructed to avoid any risk to the end product when fastened.	National Electrical Code and; Canadian Electrical Code	The Cable Management System is designed and constructed in such a manner that any risk to the end product when fastened is avoided. Checked by Consultants Europe



ISO 9001:2000
Reg. 7977-1

CONSULTANTS EUROPE bv

TECHNICAL & LEGAL EXPERTS

Address: Assured Protection Vista A.P.V Damascus, Daara Old St. Al bardah exit P.O. Box: sbenh 76 Syria	Client name: MHD.Mazen Al Malat <i>General Manager</i>	Object: Cable Management System
Contact(s) at Consultants Europe: S. Koumatchev	Report number: 230210/APV/01	Date: February 23, 2010
Evaluation performed by: Mr. David Rubio Borrajo	Within the framework of: 1. OSHA 29 CFR 1910.305 2. National Electrical Code and Canadian Electrical Code 3. NEMA VE1 – Metal Cable Tray Systems 4. NEMA VE2 – Metal Cable Tray Installation Guidelines	Location: Consultants Europe Nieuwstad 100 1381 CE Weesp The Netherlands
Requirements	In conformity with the Directive(s)	Assessment
18) Maintenance works should be able to be performed to a product in a safe way	National Electrical Code and; Canadian Electrical Code	Maintenance on the Cable Management System can be performed in a safe way. Checked by Consultants Europe
19) The installation instructions provided with the cable tray system shall address the following: 1. Intended use, including acceptable types of environment; 2. Installation guidelines, including allowable fill, maximum weight, wire secure grounding and bonding, accessibility of the system, proper support of the cable tray system	National Electrical Code and; Canadian Electrical Code and; NEMA VE 1-2009 and; NEMA VE 2-2000	<i>The items indicated in 1) and 2) and as noted also in this Design Inspection checklist under numbers 13 and 70, the items are not adequately addressed in the marketing literature or in the design instructions. This must be modified (see recommendations in conclusion of this report) and send back to Consultants Europe for verification.</i> Checked by Consultants Europe



ISO 9001:2000
Reg. 7977-1

Address: Assured Protection Vista A.P.V Damascus, Daara Old St. Al bardeh exit P.O. Box: sbenh 76 Syria	Client name: MHD.Mazen Al Malat <i>General Manager</i>	Object: Cable Management System
Contact(s) at Consultants Europe: S. Koumatchev	Report number: 230210/APV/01	Date: February 23, 2010
Evaluation performed by: Mr. David Rubio Borrajo	Within the framework of: 1. OSHA 29 CFR 1910.305 2. National Electrical Code and Canadian Electrical Code 3. NEMA VE1 – Metal Cable Tray Systems 4. NEMA VE2 – Metal Cable Tray Installation Guidelines	Location: Consultants Europe Nieuwstad 100 1381 CE Weesp The Netherlands
Requirements	In conformity with the Directive(s)	Assessment
20) All user manuals need to be present together with the product	NEMA VE-1-2009 and; NEMA VE-2-2000	<i>The user's manuals of the Cable Management System must be made clear to the operator by means of an installation manual. This must be controlled by the technical and legal experts of Consultants Europe. Checked by Consultants Europe</i>
21) Hazards for the product should be precluded or limited as much as possible (the design measures as worked into the product during design).	National Electrical Code and; Canadian Electrical Code	The Cable Management System product hazards (the design Measures as worked into the product during design) are precluded or limited as much as possible. Checked by Consultants Europe
22) For hazards that cannot be precluded, the necessary design measures must be undertaken	National Electrical Code and; Canadian Electrical Code	For hazards that cannot be precluded the necessary design measures have been undertaken. Checked by Consultants Europe

Address: Assured Protection Vista A.P.V Damascus, Daara Old St. Al bardeh exit P.O. Box: sbenh 76 Syria	Client name: MHD.Mazen Al Malat <i>General Manager</i>	Object: Cable Management System
Contact(s) at Consultants Europe: S. Koumatchev	Report number: 230210/APV/01	Date: February 23, 2010
Evaluation performed by: Mr. David Rubio Borrajo	Within the framework of: 1. OSHA 29 CFR 1910.305 2. National Electrical Code and Canadian Electrical Code 3. NEMA VE1 – Metal Cable Tray Systems 4. NEMA VE2 – Metal Cable Tray Installation Guidelines	Location: Consultants Europe Nieuwstad 100 1381 CE Weesp The Netherlands
Requirements	In conformity with the Directive(s)	Assessment
23) The product(s) must be suitable for construction works as a whole and in their separate part	National Electrical Code and; Canadian Electrical Code	The Cable Management System is suitable for constructions works. Checked by Consultants Europe
24) The product(s) must be suitable for their intended use	National Electrical Code and; Canadian Electrical Code	The Cable Management System is suitable to use for the intended use. Checked by Consultants Europe
25) The workings of a product must be subjected to regulations containing the essential requirements	National Electrical Code and; Canadian Electrical Code	The Cable Management System is subjected to the essential requirements out of the applicable regulations. Checked by Consultants Europe
26) The essential requirements must concern actions which are foreseeable	National Electrical Code and; Canadian Electrical Code	The Cable Management System was subjected to foreseeable essential requirements. Checked by Consultants Europe



ISO 9001:2000
Reg. 7977-1

CONSULTANTS EUROPE bv

TECHNICAL & LEGAL EXPERTS

Address: Assured Protection Vista A.P.V Damascus, Daara Old St. Al bardeh exit P.O. Box: sbenh 76 Syria	Client name: MHD.Mazen Al Malat <i>General Manager</i>	Object: Cable Management System
Contact(s) at Consultants Europe: S. Koumatchev	Report number: 230210/APV/01	Date: February 23, 2010
Evaluation performed by: Mr. David Rubio Borrajo	Within the framework of: 1. OSHA 29 CFR 1910.305 2. National Electrical Code and Canadian Electrical Code 3. NEMA VE1 – Metal Cable Tray Systems 4. NEMA VE2 – Metal Cable Tray Installation Guidelines	Location: Consultants Europe Nieuwstad 100 1381 CE Weesp The Netherlands
Requirements	In conformity with the Directive(s)	Assessment
27) The product must be designed and built in such a way that the loadings that are liable to act on it during its constructions and use will not lead to collapse of the whole or part of the work.	National Electrical Code and; Canadian Electrical Code	The Cable Management System is designed and built in such a way that the liable loadings acting during the construction and use do not lead to collapse of the whole or part of the work. Checked by Consultants Europe
28) The product must be designed and built in such a way that the loadings that are liable to act on it during its constructions and use will not lead to major deformations to an inadmissible degree	National Electrical Code and; Canadian Electrical Code	The Cable Management System is designed and built in such a way that the liable loadings acting during the construction and use do not lead to major deformations to an inadmissible degree. Checked by Consultants Europe



ISO 9001:2000
Reg. 7977-1

CONSULTANTS EUROPE bv

TECHNICAL & LEGAL EXPERTS

Address: Assured Protection Vista A.P.V Damascus, Daara Old St. Al bardeh exit P.O. Box: sbenh 76 Syria	Client name: MHD.Mazen Al Malat <i>General Manager</i>	Object: Cable Management System
Contact(s) at Consultants Europe: S. Koumatchev	Report number: 230210/APV/01	Date: February 23, 2010
Evaluation performed by: Mr. David Rubio Borrajo	Within the framework of: 1. OSHA 29 CFR 1910.305 2. National Electrical Code and Canadian Electrical Code 3. NEMA VE1 Metal Cable Tray Systems 4. NEMA VE2 – Metal Cable Tray Installation Guidelines	Location: Consultants Europe Nieuwstad 100 1381 CE Weesp The Netherlands
Requirements	In conformity with the Directive(s)	Assessment
29) The product must be designed and built in such a way that the loadings that are liable to act on it during its constructions and use will not lead to damage to other parts of the works or to fittings or installed equipment as a result of major deformation of the load-bearing construction	National Electrical Code and; Canadian Electrical Code	The Cable Management System is designed and built in such a way that the liable loadings acting during the construction and use do not lead to damage to other parts of the works or to fittings or installed equipment as a result of major deformation of the load-bearing. construction Checked by Consultants Europe
30) The product must be designed and built in such a way that the loadings that are liable to act on it during its constructions and use will not lead to damage by an event to an extent disproportionate to the original cause.	National Electrical Code and; Canadian Electrical Code	The Cable Management System is designed and built in such a way that the liable loadings acting during the construction and use do not lead to damage by an event to an extent disproportionate to the original cause. Checked by Consultants Europe



ISO 9001:2000
Reg. 7977-1

CONSULTANTS EUROPE bv

TECHNICAL & LEGAL EXPERTS

Address: Assured Protection Vista A.P.V Damascus, Daara Old St. Al bardeh exit P.O. Box: sbenh 76 Syria	Client name: MHD.Mazen Al Malat <i>General Manager</i>	Object: Cable Management System
Contact(s) at Consultants Europe: S. Koumatchev	Report number: 230210/APV/01	Date: February 23, 2010
Evaluation performed by: Mr. David Rubio Borrajo	Within the framework of: 1. OSHA 29 CFR 1910.305 2. National Electrical Code and Canadian Electrical Code 3. NEMA VE1 – Metal Cable Tray Systems 4. NEMA VE2 – Metal Cable Tray Installation Guidelines	Location: Consultants Europe Nieuwstad 100 1381 CE Weesp The Netherlands
Requirements	In conformity with the Directive(s)	Assessment
31) The product must be designed and built in such a way that it does not present unacceptable risks of accidents in service or in operation	National Electrical Code and; Canadian Electrical Code	The Cable Management System is designed and built in such a way that it does not present unacceptable risks of accidents during its service or operation. Checked by Consultants Europe
32) The product shall be designed efficiently on the basis of sound knowledge of the construction project and the structural requirements of the constructions works	National Electrical Code and; Canadian Electrical Code	The Cable Management System is designed efficiently on the basis of sound knowledge and the structural requirements. Checked by Consultants Europe
33) The product must be tested and verified according to the applicable standards to complete the construction procedure for economical installation of the construction works	National Electrical Code and; Canadian Electrical Code	The Cable Management System is tested and verified according to the applicable standards Checked by Consultants Europe



ISO 9001:2000
Reg. 7977-1

CONSULTANTS EUROPE bv

TECHNICAL & LEGAL EXPERTS

Address: Assured Protection Vista A.P.V Damascus, Daara Old St. Al bardeh exit P.O. Box: sbenh 76 Syria	Client name: MHD.Mazen Al Malat <i>General Manager</i>	Object: Cable Management System
Contact(s) at Consultants Europe: S. Koumatchev	Report number: 230210/APV/01	Date: February 23, 2010
Evaluation performed by: Mr. David Rubio Borrajo	Within the framework of: 1. OSHA 29 CFR 1910.305 2. National Electrical Code and Canadian Electrical Code 3. NEMA VE1 – Metal Cable Tray Systems 4. NEMA VE2 – Metal Cable Tray Installation Guidelines	Location: Consultants Europe Nieuwstad 100 1381 CE Weesp The Netherlands
Requirements	In conformity with the Directive(s)	Assessment
34) Sufficient information to assist in the design and installation of the constructions workings should be provided prior to, and updated during, the execution of the works.	National Electrical Code and; Canadian Electrical Code	All the relevant information for the Cable Management System was provided to the technical and legal experts of Consultants Europe. Checked by Consultants Europe
35) All constructions systems shall have been subjected to at least one system test to verify the competence of the system.	National Electrical Code and; Canadian Electrical Code	The Cable Management System has been subjected to at least one system test and the competence of the systems has been verified. Checked by Consultants Europe
36) All materials used shall be mutually compatible.	National Electrical Code and; Canadian Electrical Code	All the materials used for the Cable Management System are mutually compatible. Checked by Consultants Europe



ISO 9001:2000
Reg. 7977-1

CONSULTANTS EUROPE bv

TECHNICAL & LEGAL EXPERTS

Address: Assured Protection Vista A.P.V Damascus, Daara Old St. Al bardeh exit P.O. Box: sbenh 76 Syria	Client name: MHD.Mazen Al Malat <i>General Manager</i>	Object: Cable Management System
Contact(s) at Consultants Europe: S. Koumatchev	Report number: 230210/APV/01	Date: February 23, 2010
Evaluation performed by: Mr. David Rubio Borrajo	Within the framework of: 1. OSHA 29 CFR 1910.305 2. National Electrical Code and Canadian Electrical Code 3. NEMA VE1 – Metal Cable Tray Systems 4. NEMA VE2 – Metal Cable Tray Installation Guidelines	Location: Consultants Europe Nieuwstad 100 1381 CE Weesp The Netherlands
Requirements	In conformity with the Directive(s)	Assessment
37) The overall design of the product should address the load and constrains of loading imposed on the overall structure as in accordance with the stipulated requirements	National Electrical Code and; Canadian Electrical Code	The overall design of the Cable Management System addresses the load and constrains of loading imposed on the overall structures as in accordance with the relevant standards. Checked by Consultants Europe
38) The overall design of the product should address the load distribution of the arrangement on the structure during stressing and during the design life of the structure	National Electrical Code and; Canadian Electrical Code	The overall design of the Cable Management System addresses the load distribution of the arrangement on the structure during stressing and during the design life of the structure as in accordance with the relevant standards Checked by Consultants Europe
39) The overall design of the product should ensure structural stability at all times	National Electrical Code and; Canadian Electrical Code	The overall design of the Cable Management System ensures structural stability at all times. Checked by Consultants Europe



ISO 9001:2000
Reg. 7977-1

CONSULTANTS EUROPE bv

TECHNICAL & LEGAL EXPERTS

Address: Assured Protection Vista A.P.V Damascus, Daara Old St. Al bardeh exit P.O. Box: sbenh 76 Syria	Client name: MHD.Mazen Al Malat <i>General Manager</i>	Object: Cable Management System
Contact(s) at Consultants Europe: S. Koumatchev	Report number: 230210/APV/01	Date: February 23, 2010
Evaluation performed by: Mr. David Rubio Borrajo	Within the framework of: 1. OSHA 29 CFR 1910.305 2. National Electrical Code and Canadian Electrical Code 3. NEMA VE1 – Metal Cable Tray Systems 4. NEMA VE2 – Metal Cable Tray Installation Guidelines	Location: Consultants Europe Nieuwstad 100 1381 CE Weesp The Netherlands
Requirements	In conformity with the Directive(s)	Assessment
40) The components of the product shall withstand the stresses likely to occur under classified minimum temperature for storage and transport, installation and application and maximum temperature for application and during recommended installation practice and usage.	National Electrical Code and; Canadian Electrical Code	The components of the Cable Management System can withstand the stresses likely to occur under classified minimum temperature for storage and transport, installation and application and maximum temperature for application and during recommended installation practice and usage. Checked by Consultants Europe
41) The Marking on the Cable Management System shall be durable and easily legible.	National Electrical Code and; Canadian Electrical Code	The Marking on the Cable Management System is durable and easily legible. Checked by Consultants Europe
42) The manufacturer shall provide in his documentation all information necessary for the proper and safe installation and use	National Electrical Code and; Canadian Electrical Code	In the documentation of the Cable Management System all information is provided for the proper and safe installation and use. Checked by Consultants Europe



ISO 9001:2000
Reg. 7977-1

CONSULTANTS EUROPE bv

TECHNICAL & LEGAL EXPERTS

Address: Assured Protection Vista A.P.V Damascus, Daara Old St. Al hardeh exit P.O. Box: sbenh 76 Syria	Client name: MHD.Mazen Al Malat <i>General Manager</i>	Object: Cable Management System
Contact(s) at Consultants Europe: S. Koumatchev	Report number: 230210/APV/01	Date: February 23, 2010
Evaluation performed by: Mr. David Rubio Borrajo	Within the framework of: 1. OSHA 29 CFR 1910.305 2. National Electrical Code and Canadian Electrical Code 3. NEMA VE1 – Metal Cable Tray Systems 4. NEMA VE2 – Metal Cable Tray Installation Guidelines	Location: Consultants Europe Nieuwstad 100 1381 CE Weesp The Netherlands
Requirements	In conformity with the Directive(s)	Assessment
43) Any surface or edge shall not damage the insulated conductors or cables.	National Electrical Code and; Canadian Electrical Code	The surface and edges of the Cable Management System will not damage the insulated conductors or cables. Checked by Consultants Europe
44) Screws, studs or other securing devices provided shall be fitted so as not to damage the insulated conductors or cables.	National Electrical Code and; Canadian Electrical Code	The screws, studs or other securing devices provided to the Cable Management System are fitted so as not to damage the insulated conductors or cables. Checked by Consultants Europe
45) Screwed connections and other mechanical connections shall withstand the mechanical stresses during installation and normal use.	National Electrical Code and; Canadian Electrical Code	The screwed connections and other mechanical connections of the Cable Management System can withstand the mechanical stresses during installation and normal use. Checked by Consultants Europe



ISO 9001:2000
Reg. 7977-1

CONSULTANTS EUROPE bv

TECHNICAL & LEGAL EXPERTS

Address: Assured Protection Vista A.P.V Damascus, Daara Old St. Al bardeh exit P.O. Box: sbenh 76 Syria	Client name: MHD.Mazen Al Malat <i>General Manager</i>	Object: Cable Management System
Contact(s) at Consultants Europe: S. Koumatchev	Report number: 230210/APV/01	Date: February 23, 2010
Evaluation performed by: Mr. David Rubio Borraro	Within the framework of: 1. OSHA 29 CFR 1910.305 2. National Electrical Code and Canadian Electrical Code 3. NEMA VE1 – Metal Cable Tray Systems 4. NEMA VE2 – Metal Cable Tray Installation Guidelines	Location: Consultants Europe Nieuwstad 100 1381 CE Weesp The Netherlands
Requirements	In conformity with the Directive(s)	Assessment
46) Inlet openings of the product shall allow the introduction of conduits and/or the like, or the protective covering of the cable at least 1 mm into the system component, in order to maintain the mechanical protection.	National Electrical Code and; Canadian Electrical Code	The inlet openings of the Cable Management System allow the introduction of conduits and/or the like, or the protective covering of the cable at least 1 mm into the system component. Checked by Consultants Europe
47) Membranes and the like which prevent access to live parts shall withstand the mechanical stresses occurring in normal use.	National Electrical Code and; Canadian Electrical Code	Membranes and the like of the Cable Management System which prevent access to live parts can withstand the mechanical stresses occurring in normal use. Checked by Consultants Europe
48) Cable anchorage shall relieve conductors from strain in terminals or terminations by resisting the pull and twist forces on cable.	National Electrical Code and; Canadian Electrical Code	The cable anchorage of the Cable Management System relieves conductors from strain in terminals or terminations by resisting the pull and twist forces on cable. Checked by Consultants Europe



ISO 9001:2000
Reg. 7877-1

Address: Assured Protection Vista A.P.V Damascus, Daara Old St. Al bardeh exit P.O. Box: sbenh 76 Syria	Client name: MHD.Mazen Al Malat <i>General Manager</i>	Object: Cable Management System
Contact(s) at Consultants Europe: S. Koumatchev	Report number: 230210/APV/01	Date: February 23, 2010
Evaluation performed by: Mr. David Rubio Borrajo	Within the framework of: 1. OSHA 29 CFR 1910.305 2. National Electrical Code and Canadian Electrical Code 3. NEMA VE1 – Metal Cable Tray Systems 4. NEMA VE2 – Metal Cable Tray Installation Guidelines	Location: Consultants Europe Nieuwstad 100 1381 CE Weesp The Netherlands
Requirements	In conformity with the Directive(s)	Assessment
49) The product shall have adequate mechanical strength.	National Electrical Code and; Canadian Electrical Code	The Cable Management System has adequate mechanical strength. Checked by Consultants Europe
50) The product shall have adequate conductivity.	National Electrical Code and; Canadian Electrical Code	The cables used in the Cable Management System are always double isolated. Checked by Consultants Europe
51) Non-metallic system components and composite system components which might be exposed to abnormal heat due to electrical effects and deterioration of which might impair the design of the system, shall not initiate fire.	National Electrical Code and; Canadian Electrical Code	The non-metallic components and composite components of the Cable Management System which might be exposed to abnormal heat due to electrical effects and deterioration of which might impair the design of the system, do not initiate fire. Checked by Consultants Europe



ISO 9001:2000
Reg. 7977-1

Address: Assured Protection Vista A.P.V Damascus, Daara Old St. Al bardeh exit P.O. Box: sbenh 76 Syria	Client name: MHD.Mazen Al Malat <i>General Manager</i>	Object: Cable Management System
Contact(s) at Consultants Europe: S. Koumatchev	Report number: 230210/APV/01	Date: February 23, 2010
Evaluation performed by: Mr. David Rubio Borrajo	Within the framework of: 1. OSHA 29 CFR 1910.305 2. National Electrical Code and Canadian Electrical Code 3. NEMA VE1 – Metal Cable Tray Systems 4. NEMA VE2 – Metal Cable Tray Installation Guidelines	Location: Consultants Europe Nieuwstad 100 1381 CE Weesp The Netherlands
Requirements	In conformity with the Directive(s)	Assessment
52) Non metallic system components and composite system components shall not actively contribute to fire.	National Electrical Code and; Canadian Electrical Code	The non metallic components and composite components of the Cable Management System de not actively contribute to fire.
53) Non-flame propagating CTS/CDS shall either not ignite or if ignited, shall not continue to burn when the source of ignition is removed.	National Electrical Code and; Canadian Electrical Code	The non-flame propagating of the Cable Management System does not ignite or if ignited, does not continue to burn when the source of ignition is removed. Checked by Consultants Europe
54) A product, when assembled and installed according to the manufacturer's instructions, shall provide adequate protection according to the classification declared by the manufacturer.	National Electrical Code and; Canadian Electrical Code	The Cable Management System, when assembled and installed according to the manufacturer's instructions, provides adequate protection according to the classification declared by the manufacturer. Checked by Consultants Europe



ISO 9001:2000
Reg. 7977-1

CONSULTANTS EUROPE bv

TECHNICAL & LEGAL EXPERTS

Address: Assured Protection Vista A.P.V Damascus, Daara Old St. Al bardeh exit P.O. Box: sbenh 76 Syria	Client name: MHD.Mazen Al Malat <i>General Manager</i>	Object: Cable Management System
Contact(s) at Consultants Europe: S. Koumatchev	Report number: 230210/APV/01	Date: February 23, 2010
Evaluation performed by: Mr. David Rubio Borrajo	Within the framework of: 1. OSHA 29 CFR 1910.305 2. National Electrical Code and Canadian Electrical Code 3. NEMA VE1 – Metal Cable Tray Systems 4. NEMA VE2 – Metal Cable Tray Installation Guidelines	Location: Consultants Europe Nieuwstad 100 1381 CE Weesp The Netherlands
Requirements	In conformity with the Directive(s)	Assessment
55) Cable management products are, in normal use, passive in respect of electromagnetic influences (emission and immunity).	National Electrical Code and; Canadian Electrical Code	The Cable Management System is, in normal use, passive in respect of electromagnetic influences (emission and immunity). Checked by Consultants Europe
56) The entire product must meet the applicable essential requirements of the National Electrical Code and the Canadian Electrical Code	National Electrical Code and; Canadian Electrical Code	The entire Cable Management System meets the applicable essential requirements of the National Electrical Code and the Canadian Electrical Code Checked by Consultants Europe
57) Cable tray systems shall be made of either corrosion-resistant metal, such as aluminum or stainless steel or metal with a corrosion-resistant finish	NEMA VE 1-2009/ CSA C22.2 No. 126 section 4.1	The Cable Management System has a corrosion resistant finish. Checked by Consultants Europe



ISO 9001:2000
Reg. 7977-1

CONSULTANTS EUROPE bv

TECHNICAL & LEGAL EXPERTS

Address: Assured Protection Vista A.P.V Damascus, Daara Old St. Al bardeh exit P.O. Box: sbenh 76 Syria	Client name: MHD.Mazen Al Malat <i>General Manager</i>	Object: Cable Management System
Contact(s) at Consultants Europe: S. Koumatchev	Report number: 230210/APV/01	Date: February 23, 2010
Evaluation performed by: Mr. David Rubio Borraro	Within the framework of: 1. OSHA 29 CFR 1910.305 2. National Electrical Code and Canadian Electrical Code 3. NEMA VE1 – Metal Cable Tray Systems 4. NEMA VE2 – Metal Cable Tray Installation Guidelines	Location: Consultants Europe Nieuwstad 100 1381 CE Weesp The Netherlands
Requirements	In conformity with the Directive(s)	Assessment
58) Carbon steel used for cable trays shall be protected against corrosion by one of the processes as named in NEMA VE 1-2009	NEMA VE 1-2009/ CSA C22.2 No. 126 section 4.2 A - D	The essential components of the Cable Management System are sufficient strong and durable. Checked by Consultants Europe
59) For installations in highly corrosive environments, such as alkaline or acidic conditions, different or additional protective coatings may be provided in accordance with NEMA VE 1-2009	NEMA VE 1-2009/ CSA C22.2 No. 126 section 4.2.2 A - D	The Cable Management System is provided with protective coatings. Checked by Consultants Europe



ISO 9001:2000
Reg. 7977-1

CONSULTANTS EUROPE bv

TECHNICAL & LEGAL EXPERTS

Address: Assured Protection Vista A.P.V Damascus, Daara Old St. Al bardeh exit P.O. Box: sbenh 76 Syria	Client name: MHD.Mazen Al Malat <i>General Manager</i>	Object: Cable Management System
Contact(s) at Consultants Europe: S. Koumatchev	Report number: 230210/APV/01	Date: February 23, 2010
Evaluation performed by: Mr. David Rubio Borrajo	Within the framework of: 1. OSHA 29 CFR 1910.305 2. National Electrical Code and Canadian Electrical Code 3. NEMA VE1 – Metal Cable Tray Systems 4. NEMA VE2 – Metal Cable Tray Installation Guidelines	Location: Consultants Europe Nieuwstad 100 1381 CE Weesp The Netherlands
Requirements	In conformity with the Directive(s)	Assessment
60) Ferrous cable tray systems shall be provided with approved corrosion resistance suitable for the intended environmental conditions of use. Enamel-protected steel cannot be used outdoors or indoor wet locations.	National Electrical Code and; Canadian Electrical Code and; NEMA VE 1-2009	<i>The marketing literature indicates the use of painted cable tray systems for use in an external environment, food-industry like environment and marine-type environment. These uses would not be in compliance with the National and Canadian Electrical Code. More information for acid type, alkaline type, halogen and abrasive type environments is needed to determine acceptability. This must be mentioned in the users manual (see recommendations in conclusion of this report) and send back to Consultants Europe for verification. Checked by Consultants Europe</i>
61) Carbon steel nuts and bolts shall be protected against corrosion by one of the processes named in NEMA VE 1-2009	NEMA VE 1-2009/ CSA C22.2 No. 126 section 4.2.3 A and B and; ASTM B 633	The Cable Management System is protected when needed by one of the processes. Checked by Consultants Europe



Address: Assured Protection Vista A.P.V Damascus, Daara Old St. Al bardah exit P.O. Box: sbenh 76 Syria	Client name: MHD.Mazen Al Malat <i>General Manager</i>	Object: Cable Management System
Contact(s) at Consultants Europe: S. Koumatchev	Report number: 230210/APV/01	Date: February 23, 2010
Evaluation performed by: Mr. David Rubio Borrajo	Within the framework of: 1. OSHA 29 CFR 1910.305 2. National Electrical Code and Canadian Electrical Code 3. NEMA VE1 – Metal Cable Tray Systems 4. NEMA VE2 – Metal Cable Tray Installation Guidelines	Location: Consultants Europe Nieuwstad 100 1381 CE Weesp The Netherlands
Requirements	In conformity with the Directive(s)	Assessment
62) Clauses 4.3.2 to 4.3.7 of NEMA VE 1-2009 provide the typical dimensions used in industry. Other dimensions shall also be acceptable. Dimensions are based on rationalized conversions.	NEMA VE 1-2009/ CSA C22.2 No. 126 section 4.3.1 and; Clauses 4.3.2 to 4.3.7	The Cable Management System is in accordance with the typical or other acceptable dimensions. Checked by Consultants Europe
63) Cable tray systems shall be free from burrs or other sharp projections that could cause jacket during installation	NEMA VE 1-2009/ CSA C22.2 No. 126 section 4.4	The Cable Management System is free from burrs or other sharp projections. Checked by Consultants Europe
64) Fasteners used for connection and assembly of a cable tray system shall be supplied according to the manufacturer's instructions and shall comply with the requirements of NEMA VE 1-2009	NEMA VE 1-2009/ CSA C22.2 No. 126 section 4.6 and; Clause 5.1	The fasteners used for connection are in accordance with instructions. Checked by Consultants Europe
65) Cable tray systems shall be provided with connection means meeting the requirements of NEMA VE 1-2009	NEMA VE 1-2009/ CSA C22.2 No. 126 section 4.7.1 and; Clause 5.1	The Cable Management System has connection means according to NEMA VE 1-2009. Checked by Consultants Europe



ISO 9001:2000
Reg. 7977-1

CONSULTANTS EUROPE bv

TECHNICAL & LEGAL EXPERTS

Address: Assured Protection Vista A.P.V Damascus, Daara Old St. Al bardeh exit P.O. Box: sbenh 76 Syria	Client name: MHD.Mazen Al Malat <i>General Manager</i>	Object: Cable Management System
Contact(s) at Consultants Europe: S. Koumatchev	Report number: 230210/APV/01	Date: February 23, 2010
Evaluation performed by: Mr. David Rubio Borrajo	Within the framework of: 1. OSHA 29 CFR 1910.305 2. National Electrical Code and Canadian Electrical Code 3. NEMA VE1 – Metal Cable Tray Systems 4. NEMA VE2 – Metal Cable Tray Installation Guidelines	Location: Consultants Europe Nieuwstad 100 1381 CE Weesp The Netherlands
Requirements	In conformity with the Directive(s)	Assessment
66) Cable tray systems where paint or additional coatings are applied to components of the cable tray system, means shall be provided to ensure measured resistance in accordance with tests of NEMA VE 1-2009	NEMA VE 1-2009/ CSA C22.2 No. 126 section 4.7.2 and; Clause 5.1	The Cable Management System is provided with measured resistance in accordance. Checked by Consultants Europe
67) Straight sections of cable tray shall meet the requirements of the test specified in NEMA VE 1-2009 Clauses	NEMA VE 1-2009/ CSA C22.2 No. 126 section 4.8.1 and; Clauses 5.1 and 5.2	The Cable Management System meet the requirements. Checked by Consultants Europe
68) A concentrated static load is not included in tables 1 and 2 of NEMA VE 1-2009. Some user applications may require that given concentrated static load be imposed above the working load. When so specified, the concentrated static load may be converted to an equivalent uniform load as shown in formula in NEMA VE 1-2009	NEMA VE 1-2009/ CSA C22.2 No. 126 section 4.8.2 and; Tables 1 and 2	The Cable Management System is in compliance with regulations and guidelines named. Checked by Consultants Europe



ISO 9001:2000
Reg. 7977-1

CONSULTANTS EUROPE bv

TECHNICAL & LEGAL EXPERTS

Address: Assured Protection Vista A.P.V Damascus, Daara Old St. Al bardeh exit P.O. Box: sbenh 76 Syria	Client name: MHD.Mazen Al Malat <i>General Manager</i>	Object: Cable Management System
Contact(s) at Consultants Europe: S. Koumatchev	Report number: 230210/APV/01	Date: February 23, 2010
Evaluation performed by: Mr. David Rubio Borrajo	Within the framework of: 1. OSHA 29 CFR 1910.305 2. National Electrical Code and Canadian Electrical Code 3. NEMA VE1 – Metal Cable Tray Systems 4. NEMA VE2 – Metal Cable Tray Installation Guidelines	Location: Consultants Europe Nieuwstad 100 1381 CE Weesp The Netherlands
Requirements	In conformity with the Directive(s)	Assessment
69) Channel cable tray straight sections not exceeding 150 mm in width and 50 mm in depth need not to be load-tested in accordance to clause 5.2 NEMA VE 1-2009	NEMA VE 1-2009/ CSA C22.2 No. 126 section 4.8.3 and; Clause 5.8.3	The Cable Management System is in compliance with regulations and guidelines named. Checked by Consultants Europe
70) Where cable trays support individual conductors and if the conductors pass from one cable tray to another or from a cable tray to a raceway or from a cable tray to the conductor termination, the distance between the cable tray and raceway or other cable tray shall not exceed 1.8m. The conductors shall be secured at the transition point and protected from physical damage. Bonding shall be maintained between the sections. Supports shall be provided where cable enters raceway or other enclosures from the cable tray system. Cable trays shall be supported at intervals in accordance with the installation instructions.	National Electrical Code and; Canadian Electrical Code and; NEMA VE 1-2009	<i>No information was provided regarding transitional areas of installation. This must be modified (see recommendations in conclusion of this report) and send back to Consultants Europe for verification.</i> Checked by Consultants Europe



ISO 9001:2000
Reg. 7977-1

CONSULTANTS EUROPE bv

TECHNICAL & LEGAL EXPERTS

Address: Assured Protection Vista A.P.V Damascus, Daara Old St. Al bardeh exit P.O. Box: sbenh 76 Syria	Client name: MHD.Mazen Al Malat <i>General Manager</i>	Object: Cable Management System
Contact(s) at Consultants Europe: S. Koumatchev	Report number: 230210/APV/01	Date: February 23, 2010
Evaluation performed by: Mr. David Rubio Borrajo	Within the framework of: 1. OSHA 29 CFR 1910.305 2. National Electrical Code and Canadian Electrical Code 3. NEMA VE1 – Metal Cable Tray Systems 4. NEMA VE2 – Metal Cable Tray Installation Guidelines	Location: Consultants Europe Nieuwstad 100 1381 CE Weesp The Netherlands
Requirements	In conformity with the Directive(s)	Assessment
71) Test of electrical continuity of connections shall be made in accordance to NEMA VE 1-2009 if required	NEMA VE 1-2009/ CSA C22.2 No. 126 section 5 and; Clause 5.2.9	Test is made in accordance to guideline. Checked by Consultants Europe
72) Dimensions and measurements marked on the product shall include SI units. Markings expressed in inch-pound units shall be optional	NEMA VE 1-2009/ CSA C22.2 No. 126 section 6.1 and; Annex A	The Cable Management System is in compliance with regulations and guidelines named. Checked by Consultants Europe
73) Transportation and packaging instructions	NEMA VE 1-2009/ CSA and; National Electrical Code and; Canadian Electrical Code	Clear instructions must be made in the users manual or installation manual for the methods of packaging and transportation. Also other relevant instructions that contributes to the safety must be added to the users or installation manual.



ISO 9001:2000
Reg. 7977-1

CONSULTANTS EUROPE bv

TECHNICAL & LEGAL EXPERTS

Address: Assured Protection Vista A.P.V Damascus, Daara Old St. Al bardeh exit P.O. Box: sbenh 76 Syria	Client name: MHD.Mazen Al Malat <i>General Manager</i>	Object: Cable Management System
Contact(s) at Consultants Europe: S. Koumatchev	Report number: 230210/APV/01	Date: February 23, 2010
Evaluation performed by: Mr. David Rubio Borrajo	Within the framework of: 1. OSHA 29 CFR 1910.305 2. National Electrical Code and Canadian Electrical Code 3. NEMA VE1 – Metal Cable Tray Systems 4. NEMA VE2 – Metal Cable Tray Installation Guidelines	Location: Consultants Europe Nieuwstad 100 1381 CE Weesp The Netherlands
Requirements	In conformity with the Directive(s)	Assessment
74) Each straight section of cable tray and each fitting shall be marked in a permanent and readily visible manner the requirements met in NEMA VE 1-2009	NEMA VE 1-2009/ CSA C22.2 No. 126 section 6.1.2 and; Table 1 and; National Electrical Code and; Canadian Electrical Code	The Cable Management System is in compliance with regulations and guidelines named. Checked by Consultants Europe
<i>The company Assured Protection Vista needs to follow up the assessments indicated in bold and italic. The indicated provisions need to be supported with digital photographs and the required information needs to be made available to Consultants Europe as soon as possible. This design inspection report is based on the samples delivered to Consultants Europe. Consultants Europe cannot be held responsible for the production of the Cable Management System to be of the same quality.</i>		



ISO 9001:2000
Reg. 7977-1

3. TEST REPORTS

Test reports based on Expertise report of Consultants Europe for Assured Protection Vista.

3.1 Test Description

Customer : Assured Protection Vista
Damascus, Daara Old St. Al bardeh exit
P.O. Box: sbenh 76
Syria

Order no. customer : 030709/APV/05

Project : Cable Management System

Material : C-steel

Test Sample : As described below Weesp : 2009-07-01

DESCRIPTION test sample

Specimen no.

F1127	Solid Cable Tray "trunking" SCT
F1128	Perforated Cable Tray PCT
F1129	Cable Tray Cover CTC
F1130	Light Cable Ladder LCL
F1131	Medium Cable Ladder MCL
F1132	Heavy Cable Ladder HCL
F1133	Cable Ladder Cover CLC

3.2 Test Results

TENSILE TEST	EN	[Transverse]	[Test temperature ° C: [ambient]		
Specimen no.	Dimensions [mm]	Cross section [mm ²]	Rp0.2 [MPa]	Rm [MPa]	A80 [%]
F1127	20.01 x 2.02	40.4	144	289	44.5
F1128	4.05 x 1.60	6.5	265	391	15.8
F1129	20.02 x 1.98	39.6	276	385	35.6
F1130	20.00 x 1.99	39.8	242	379	19.6
F1131	20.01 x 2.01	40.2	236	335	27.3
F1132	20.03 x 2.02	40.5	254	348	40.6
F1133	20.01 x 1.99	39.9	278	361	24.4
Requirements			Min. 185	290-510	Min. 16
S185					



ISO 9001:2000
Reg. 7977-1

Specimen no.	CHEMICAL COMPOSITION [OES]					[WT %]			
	C	Si	Mn	P	S	Cr	Ni	Al	Cu
F1127	<0.01	0.02	0.10	0.005	0.005	0.02	0.02	0.06	0.03
F1128	0.01	0.12	0.65	0.071	0.010	0.02	0.03	0.03	0.04
F1129	<0.01	0.13	0.35	0.065	0.013	0.02	0.02	0.05	0.02
F1130	<0.01	0.10	0.19	0.034	0.007	0.02	0.02	0.08	0.05
F1131	<0.01	0.16	0.25	0.048	0.009	0.02	0.03	0.07	0.06
F1132	<0.01	0.11	0.47	0.014	0.008	0.02	0.04	0.04	0.04
F1133	<0.01	0.10	0.28	0.009	0.011	0.02	0.01	0.06	0.03
Requirements	-	-	-	-	-	-	-	-	-
S185									

Remark: The results are an average of at least 3 measurements.

ZINC LAYER THICKNESS

Specimen no.	[µm]				Average
F1127	197	119	100	87	126
F1128	101	97	90	84	93
F1129	129	113	105	97	111
F1130	102	94	125	103	106
F1131	131	158	114	137	135
F1132	100	109	209	87	98
F1133	106	97	84	125	103

CONCLUSIONS/ REMARKS

The results meet the specified requirements



ISO 9001:2000
Reg. 7977-1

CONSULTANTS EUROPE bv

TECHNICAL & LEGAL EXPERTS

3.3

Zinc Layer Thickness

Micro photos

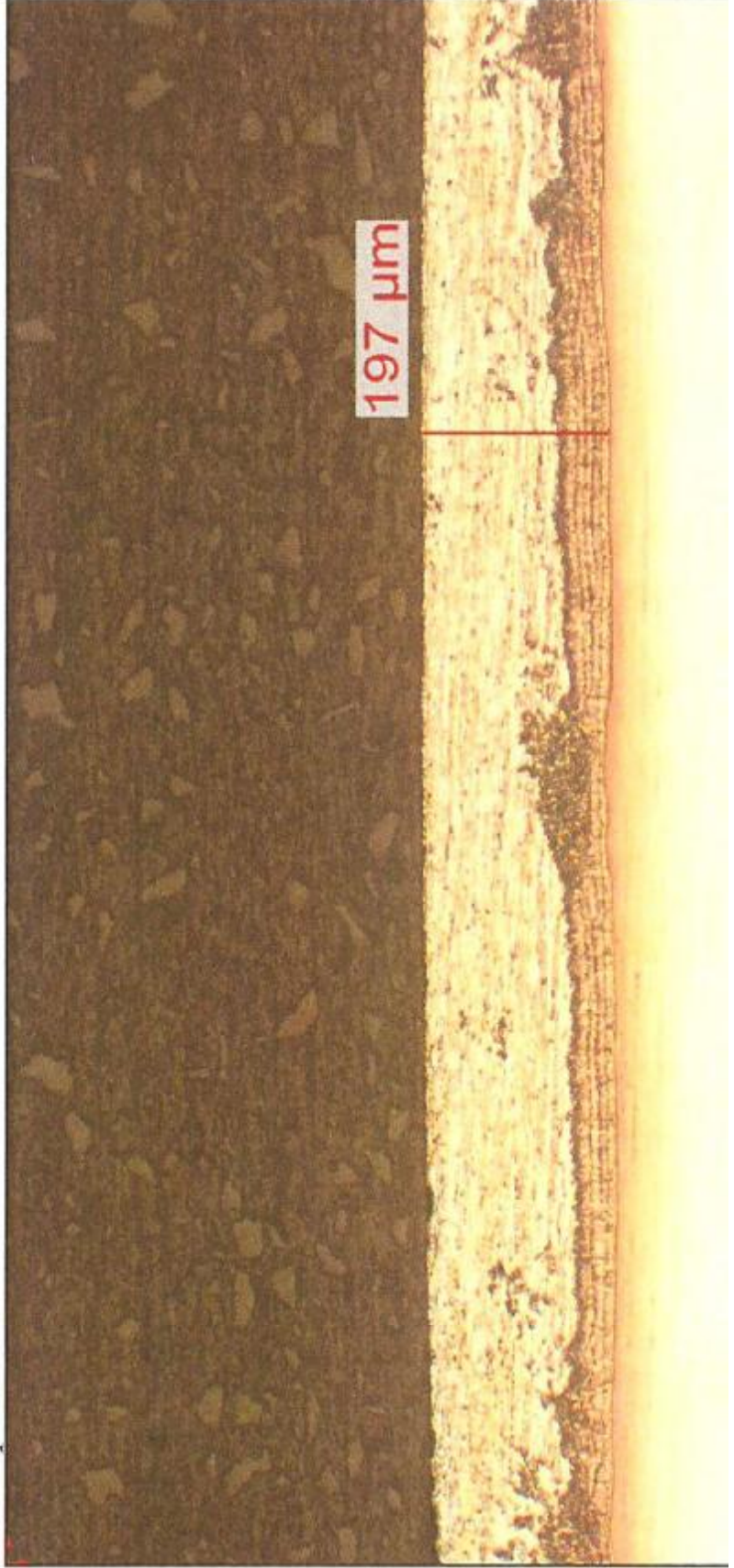

Cross-section
microstructure

Etchant:
Nital

Photographed
with $M \approx 100 \times$



ISO 9001:2000
Reg. 7977-1

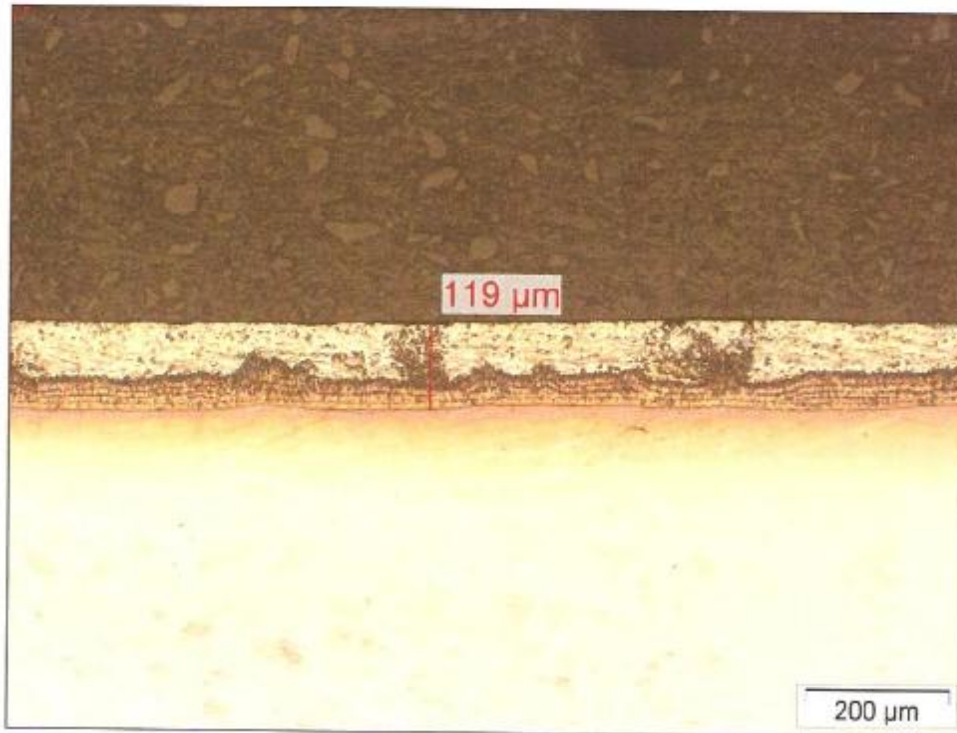

Cross-section
microstructure

Etchant:
Nital

Photographed
with $M \approx 100 \times$

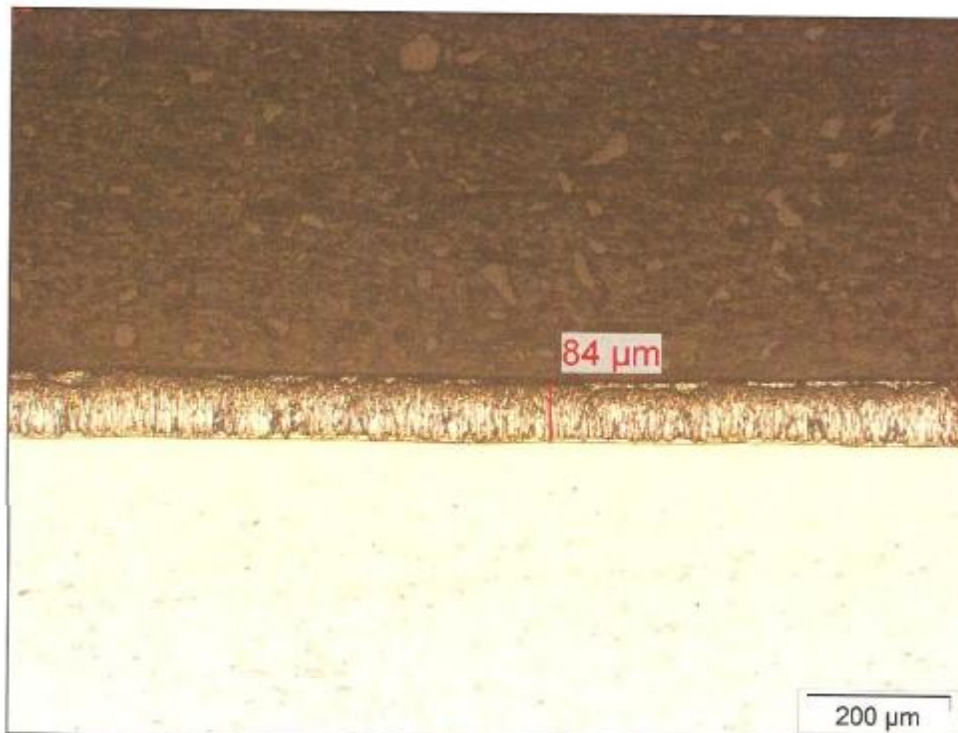

Cross-section
microstructure

Etchant:
Nital

Photographed
with $M \approx 100 \times$



ISO 9001:2000
Reg. 7977-1

CONSULTANTS EUROPE bv

TECHNICAL & LEGAL EXPERTS

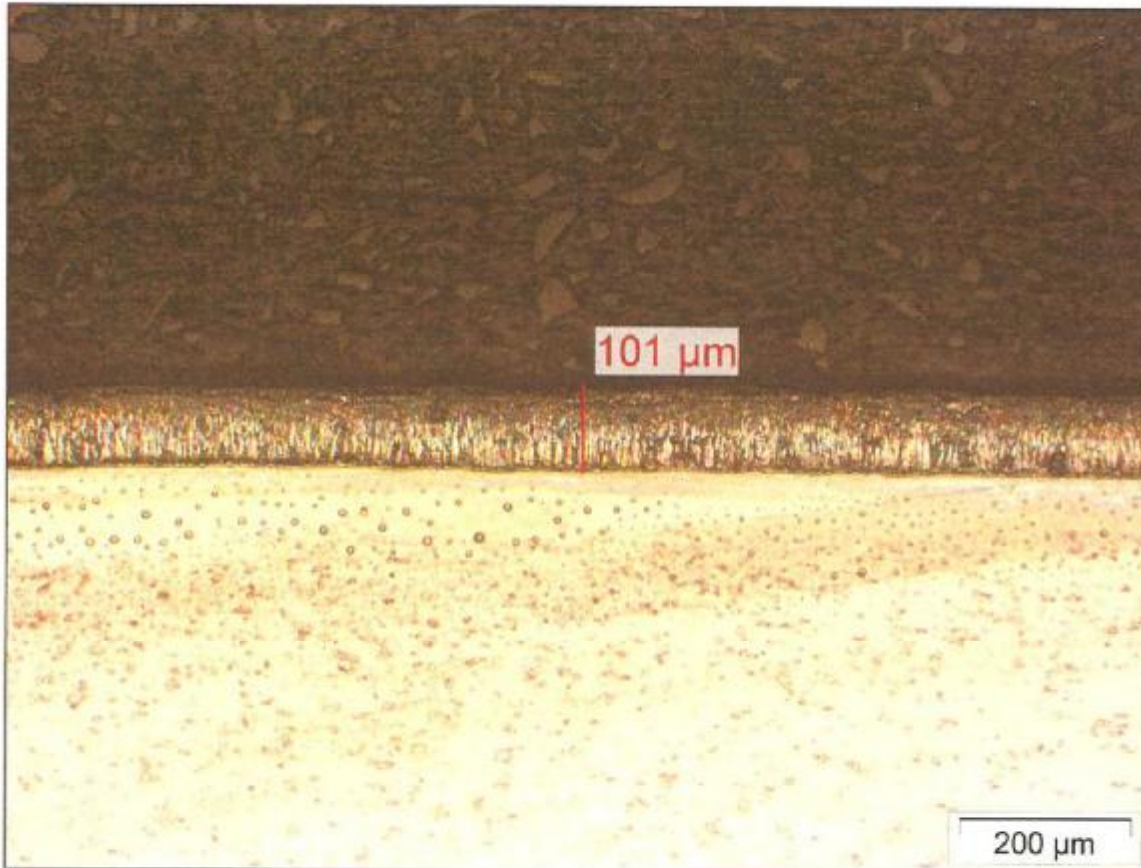

Cross-section
microstructure

Etchant:
Nital

Photographed
with $M \approx 100 \times$

دمشق في 2010/6/30

إلى من يهمه الأمر:

نحن شركة إل تيل الشرق الأوسط نشهد بأن السلالم التي تم غلفتها في معامنا لصالح السيد محمد مأمون المط والسيد محمد مازن المط " شركة APV "

قد تمت غلفتها وفق المواصفة التالية: ISO 1461/1999

تم منح هذه الشهادة بناءً على طلب السادة شركة APV

مع فائق الاحترام والتقدير

مدير معمل الغلفنة
ك. محمد بسام الزايد

ELTEL
Middle East
إل تيل الشرق الأوسط
دمشق سوريا - س.ت. ٥٨٤٨

هاتف : 00963116941480

هاتف : 00963116941481

فاكس : 00963116941482

EMAIL: bassam@eltelme.com

إلى من يهمله الأمر ,,,,

إن السادة شركة إل - تيل الشرق الأوسط ((للغلفنة)) المحترمين صاحبة ترخيص
صناعي رقم : ((15849))

و المرخصة من وزارة الصناعة بتاريخ : ((30\1\2005))

يضم إختصاص عمل الشركة غلجنة المعادن مثل : حوامل الكابلات المعدنية و أبراج
الإتارة على الحامي وفق درجات حرارة مبنية على أسس مواصفات بريطانية .

تم حصول شركتنا على عدة شهادات تؤكد استخدامنا لمواد الغلجنة لحماية منتجاتنا و
تأكيد جودتها و متانتها وفق المواصفة رقم : **BS EN ISO 146:1999** ||

و مازالت شركتنا حتى تاريخه قائمة على نظام العمل بغلجنة منتجاتنا ضمن معام
السادة شركة إل - تيل الشرق الأوسط المحترمين .

شاكرين حسن تعاونكم معنا ,,,,

وتفضلوا بقبول فائق الإحترام والتقدير ,,,,

2010\2\4

ELTEL
Middle East
إل تيل الشرق الأوسط
دمشق سوريا - ص.ت 0148

GALVANIZERS ASSOCIATION

This is to certify that

ELTEL Middle East

is an Affiliate Member of Galvanizers Association

Date of Issue: 1st January 2009

Date of Expiry: 31st December 2009



Chairman, Galvanizers Association



GA galvanizers association

This is to certify that

Eltel Middle East

is an Affiliate Member of Galvanizers Association

Date of Issue: 1st January 2005

Date of Expiry: 31st December 2005



Chairman, Galvanizers Association



HOT DIP GALVANIZING PROCESS ACCORDING TO BS 729



NOTES:

- THIS PROCESS IS "DRY PROCESS"
- SILICON CONTENT OF STEEL PREFERABLY < 0.04%
- 100g/m² = 14 μm ZINC
- ZINC BATH DIL. : 14.0mm1.4mm2.0m

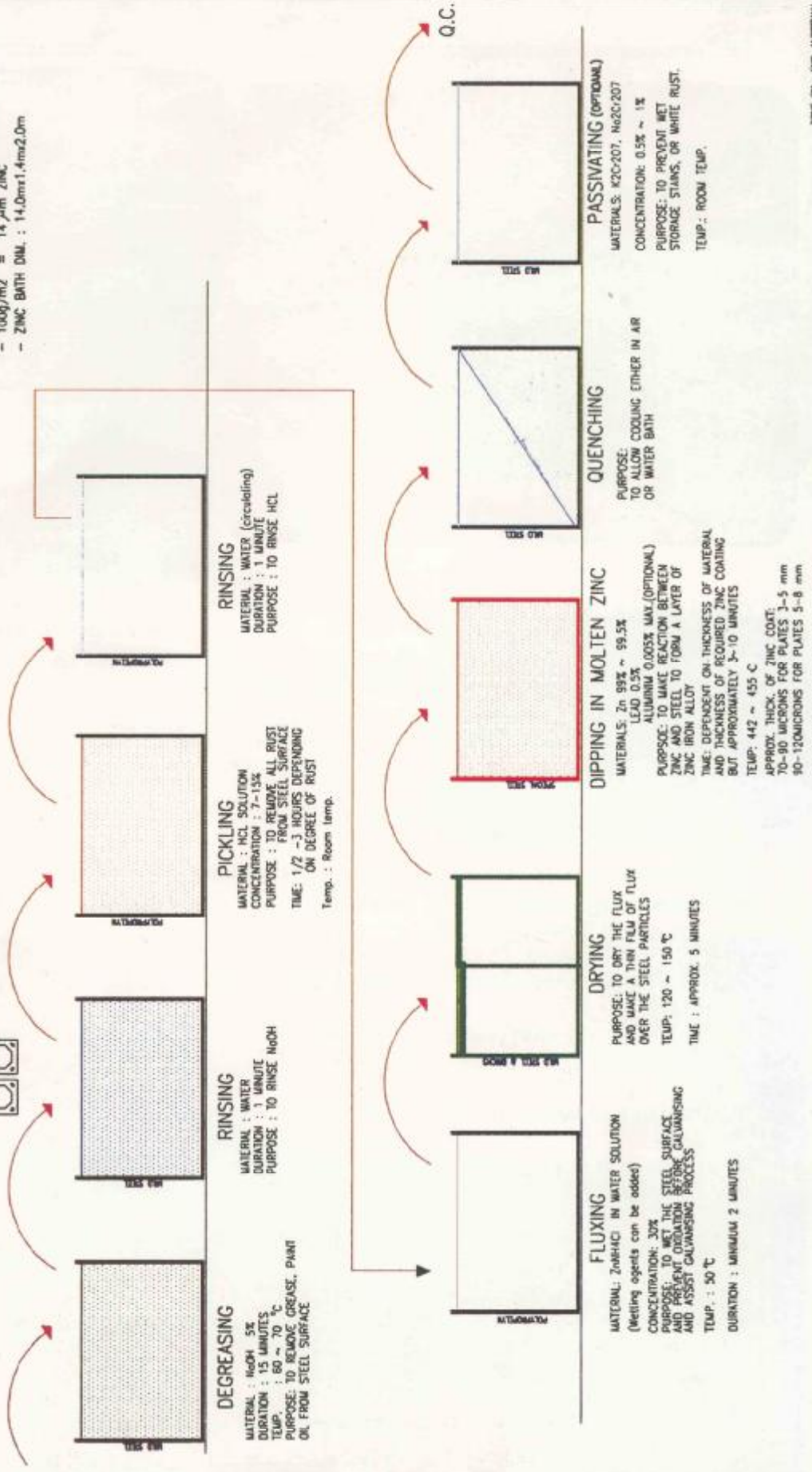
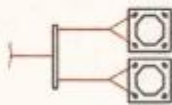

DEGREASING

MATERIAL : NaOH 5%
 DURATION : 15 MINUTES
 TEMP. : 60 ~ 70 °C
 PURPOSE : TO REMOVE GREASE, PAINT OIL FROM STEEL SURFACE

RINSING

MATERIAL : WATER
 DURATION : 1 MINUTE
 PURPOSE : TO RINSE NaOH

PICKLING

MATERIAL : HCL SOLUTION
 CONCENTRATION : 7-15%
 PURPOSE : TO REMOVE ALL RUST FROM STEEL SURFACE
 TIME : 1/2 - 3 HOURS DEPENDING ON DEGREE OF RUST
 Temp. : Room temp.

RINSING

MATERIAL : WATER (circulating)
 DURATION : 1 MINUTE
 PURPOSE : TO RINSE HCL

FLUXING

MATERIAL : Zn/HCl IN WATER SOLUTION (Melting agents can be added)
 CONCENTRATION: 30%
 PURPOSE: TO WET THE STEEL SURFACE AND PREVENT OXIDATION BEFORE GALVANIZING AND ASSIST GALVANIZING PROCESS
 TEMP. : 50 °C
 DURATION : MINIMUM 2 MINUTES

DRYING

PURPOSE: TO DRY THE FLUX AND MAKE A THIN FILM OF FLUX OVER THE STEEL PARTICLES
 TEMP: 120 ~ 150 °C
 TIME : APPROX. 5 MINUTES

DIPPING IN MOLTEN ZINC

MATERIALS: Zn 99% ~ 99.5%
 LEAD 0.3%
 ALUMINUM 0.005% MAX.(OPTIONAL)
 PURPOSE: TO MAKE REACTION BETWEEN ZINC AND STEEL TO FORM A LAYER OF ZINC IRON ALLOY
 TIME: DEPENDENT ON THICKNESS OF MATERIAL AND THICKNESS OF REQUIRED ZINC COATING BUT APPROXIMATELY 3-10 MINUTES
 TEMP: 442 ~ 455 °C
 APPROX. THICK. OF ZINC COAT: 70-90 MICRONS FOR PLATES 3-5 mm
 80-120MICRONS FOR PLATES 5-8 mm

QUENCHING

PURPOSE: TO ALLOW COOLING EITHER IN AIR OR WATER BATH

PASSIVATING (OPTIONAL)

MATERIALS: K2Cr2O7, Na2Cr2O7
 CONCENTRATION: 0.5% ~ 1%
 PURPOSE: TO PREVENT MET STORAGE STAINS, OR WHITE RUST.
 TEMP.: ROOM TEMP.

Table 1. Hence the total number of articles tested equals the number of articles required to provide one reference area multiplied by the appropriate number from the last column of Table 1 related to the size of the lot (or the total number of articles galvanized if that is less). Alternatively, sampling procedures selected from ISO 2859 shall be used.

NOTE $10,000 \text{ mm}^2 = 100 \text{ cm}^2$

$1,000 \text{ mm}^2 = 10 \text{ cm}^2$

2 m^2 is typically $200 \text{ cm} \times 100 \text{ cm}$; $10,000 \text{ mm}^2$ is typically $10 \text{ cm} \times 10 \text{ cm}$; $1,000 \text{ mm}^2$ is typically $10 \text{ cm} \times 1 \text{ cm}$.

In cases b), c) and d), the thickness on each reference area shall be equal to or greater than the 'local coating thickness' values given in Table 2 or 3 as appropriate. The mean thickness on all reference areas in a sample shall be equal to or greater than the mean coating thickness values given in Table 2 or 3 as appropriate.

When the zinc coating thickness is determined by the magnetic method in accordance with EN ISO 2178, the reference areas shall be within and representative of those that would have been chosen for the gravimetric method.

When more than five articles have to be taken to make up a reference area of at least $1,000 \text{ mm}^2$, a single magnetic measurement shall be taken on each article if a suitable area of significant surface exists; if not, the gravimetric test shall be used.

Within each reference area, which should be at least $1,000 \text{ mm}^2$, a minimum of five magnetic test readings shall be taken coated areas. If any of the individual readings is lower than the values in Tables 2 and 3, this is irrelevant, as only the mean value over the whole of each reference area is required to be equal or greater than the local thickness given in the table. The mean coating thickness for all reference areas shall be calculated in a similar way for the magnetic test as for the gravimetric test (EN ISO 1460).

Thickness measurements shall not be taken on cut surfaces or areas less than 10 mm from edges, flame cut surfaces or corners (see C.1.3).

Table 2 – Coating minimum thickness on samples that are not centrifuged

Article and its thickness	Local coating thickness (minimum) ^a μm	Mean coating thickness (minimum) ^b μm
Steel $\geq 6 \text{ mm}$	70	85
Steel $\geq 3 \text{ mm}$ to $< 6 \text{ mm}$	55	70
Steel $\geq 1.5 \text{ mm}$ to $< 3 \text{ mm}$	45	55
Steel $< 1.5 \text{ mm}$	35	45
Castings $\geq 6 \text{ mm}$	70	80
Castings $< 6 \text{ mm}$	60	70
^a See 3.8		
^b See 3.9		

NOTE 2 Table 2 is for general use; individual product standards may include different requirements including different categories of thickness. A requirement for thicker coatings or additional requirements can be added without otherwise affecting conformity to this standard.

The local coating thickness in Table 2 shall only be determined in relation to reference areas selected in accordance with 6.2.3.



ISO 9001:2000
Reg. 7977-1

4. CONCLUSION AND RECOMMENDATIONS

The following points are to be adapted to confirm compliance with the National Electrical Code and the Canadian Electrical Code;

The following numbers refer to the checkpoints as named in the Design Inspection Evaluation in this report.

9) Cable trays shall have suitable strength and rigidity to support the intended wiring.

Recommendation: use ANSI/NEMA VE-1 as a guideline in determining how to address the correct selection of A.P.V cable tray systems for the intended use. Cable tray strengths, proper loading and support should be addressed in installation instructions.

13) Cable trays and their fittings are to be identified for the intended use. Allowed uses in accordance with support system for service conductors, feeders, branch circuits, communications circuits, control circuits, and signaling circuits. Only the wiring methods noted in Table 392.3(A) can be used with cable trays.

Recommendation: Provide installation instructions and markings on the unit or packaging that specifically identifies the intended use and any limitations.

For example: "Indoor Use only" or "Indoor/Outdoor Use."

The intended use should also specify any restrictions, such as whether or not the cable tray is intended for use in hazardous locations.

15) All metallic cable tray systems are to be bonded and grounded (protectively earthed). A steel or aluminum cable tray system can serve as the equipment grounding conductor means under the conditions named in the National Electrical and Canadian Electrical Code.

Recommendation: Provide installation instructions that specify appropriate bonding methods and clarify if the cable tray systems can be used as equipment grounding conductors. If so, it is recommended that third party certification, such as through UL or Intertek, be pursued to confirm acceptability of the cable tray system as an equipment grounding conductor.



21) The installation instructions provided with the cable tray system shall address the proper requirements.

Recommendation: Assure that the installation instructions are provided with specifically address of these items.

62) Ferrous cable tray systems shall be provided with approved corrosion resistance suitable for the intended environmental conditions of use. Enamel-protected steel cannot be used outdoors or indoor wet locations.

Recommendation: Amend the intended cable tray guidelines in the literature to the uses allowed by the National Electrical Code and the Canadian Electrical Code.

72) Where cable trays support individual conductors and if the conductors pass from one cable tray to another or from a cable tray to a raceway or from a cable tray to the conductor termination, the distance between the cable tray and raceway or other cable tray shall not exceed 1.8m. The conductors shall be secured at the transition point and protected from physical damage. Bonding shall be maintained between the sections. Supports shall be provided where cable enters raceway or other enclosures from the cable tray system. Cable trays shall be supported at intervals in accordance with the installation instructions.

Recommendation: Use proper securing of conductors and cables, proper installation at transition points and proper support of cable trays should all be addressed in installation instructions. This information should be specific to the type of cable tray system.

We recommend the following step's to assure the approval process to achieve compliance with the National Electrical Code and the Canadian Electrical Code;

- A. Evaluate the cable tray system designs, shipping, handling, storing and installation to the requirements in NEMA VE-1-2002 and NEMA VE-2-2006 to confirm compliance to the National Electrical Code and Canadian Electrical Code requirements.
- B. Determine intended uses. Ensure the installation instructions address all intended use, maintenance, transport concerns for the cable tray system. Note that these items should be separately addressed for each of the cable tray types.
- C. If a particular cable tray system is intended for use as an equipment grounding conductor, it should be evaluated by an NRTL (U.S. Nationally Recognized Testing Laboratory) as to its acceptability as an equipment grounding conductor.



ISO 9001:2000
Reg. 7977-1

CONSULTANTS EUROPE bv

TECHNICAL & LEGAL EXPERTS

If required Consultants Europe can comply a complete installation and users manual. These will be custom made by the legal experts at Consultants Europe and will be in compliance with European, Canadian and United States legacy. This manual can also be used as a base for future projects that have to be in compliance with European, Canadian or United States legacy.

For this Consultants Europe can comply an quotation for Assured Protection Vista.



ISO 9001:2000
Reg. 7977-1

Annex A – Drawings (main components)

Products of Assured Protection Vista that have been investigated.

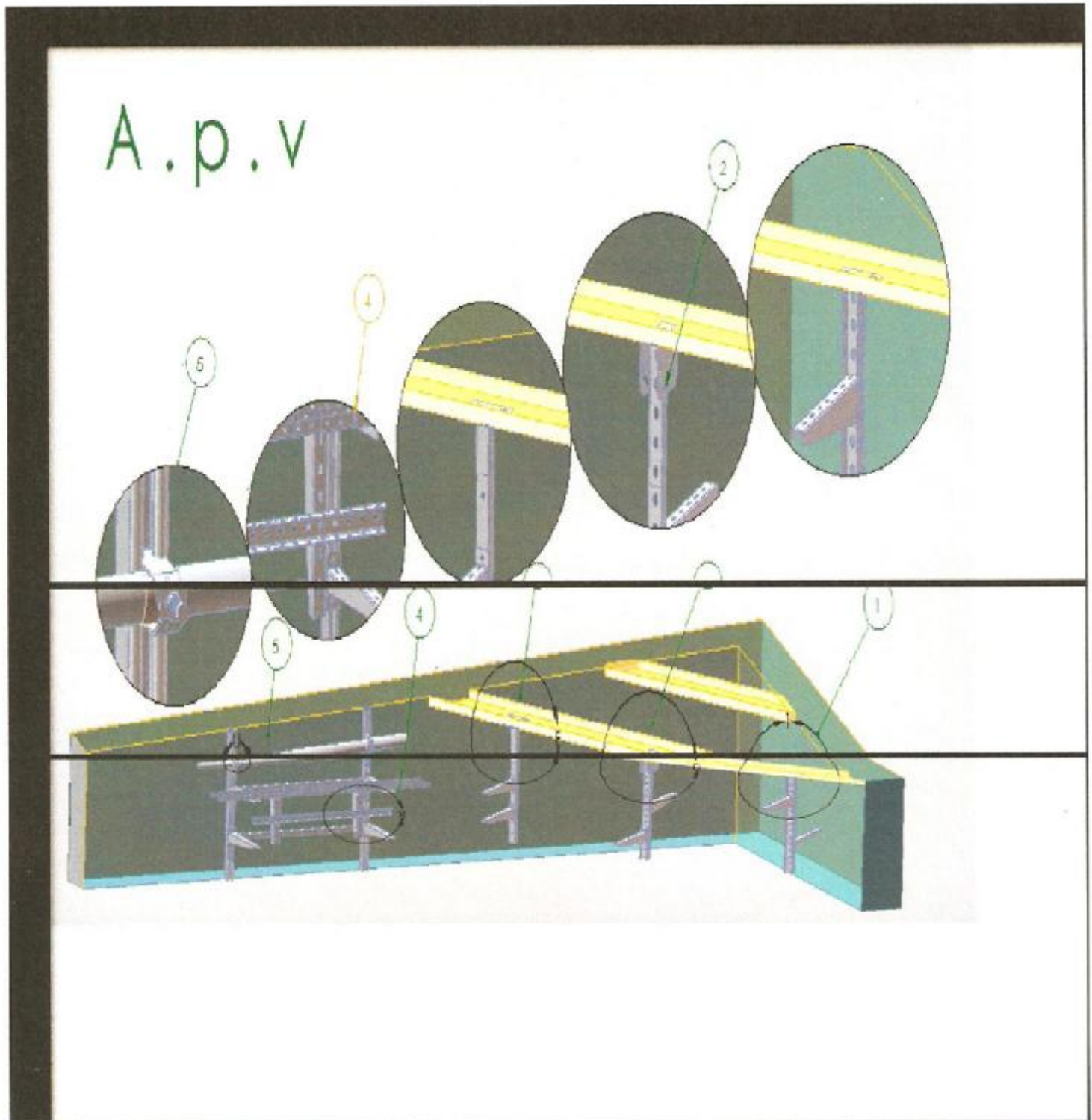

Fig. 1 - Cable ladder with supports

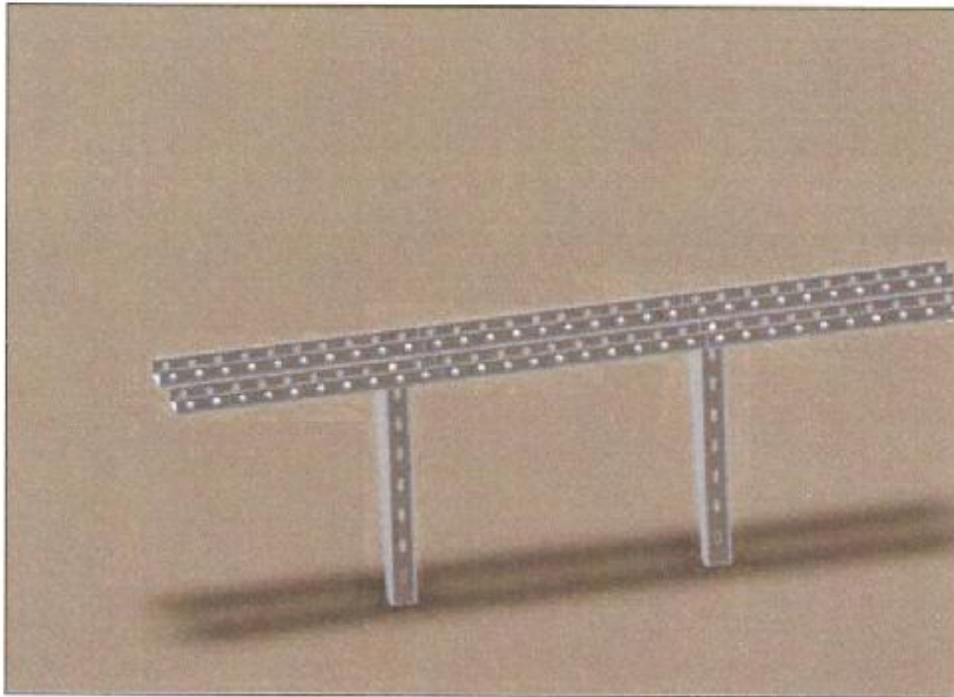

Fig. 2 - Clump



Fig. 3 - Ceiling Support

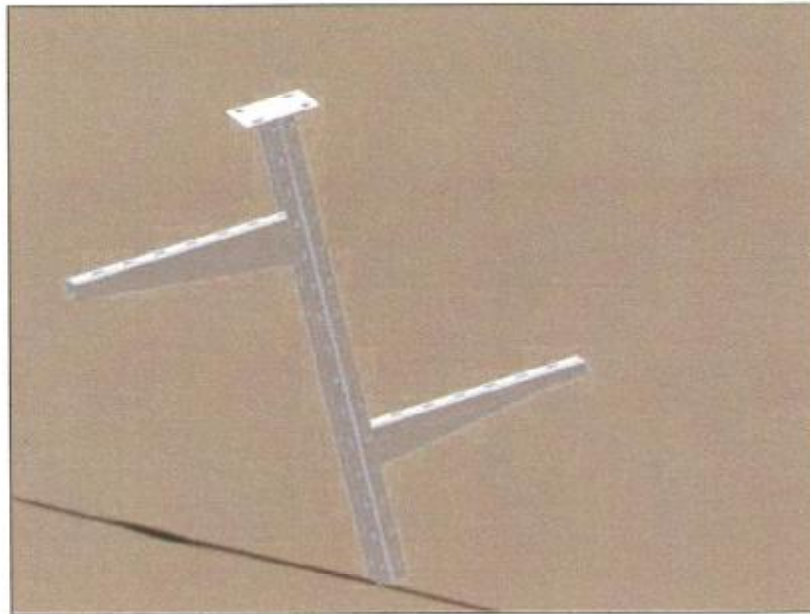

Fig. 4 - Wall support 1

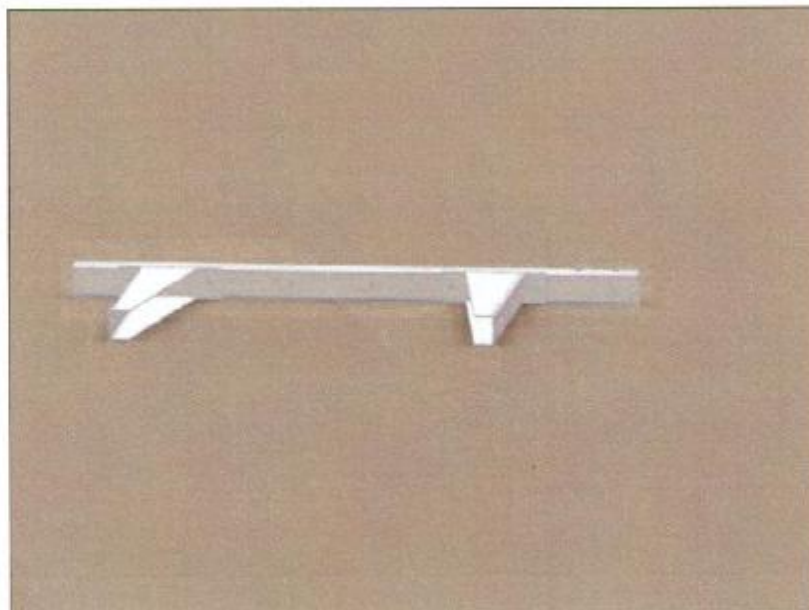

Fig. 5 - Wall support 2

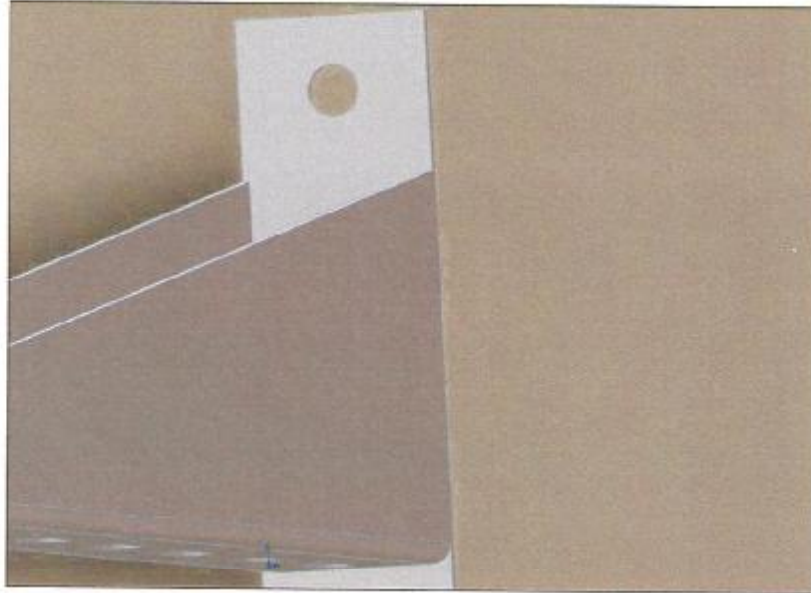

Fig. 6 - Nut articulated

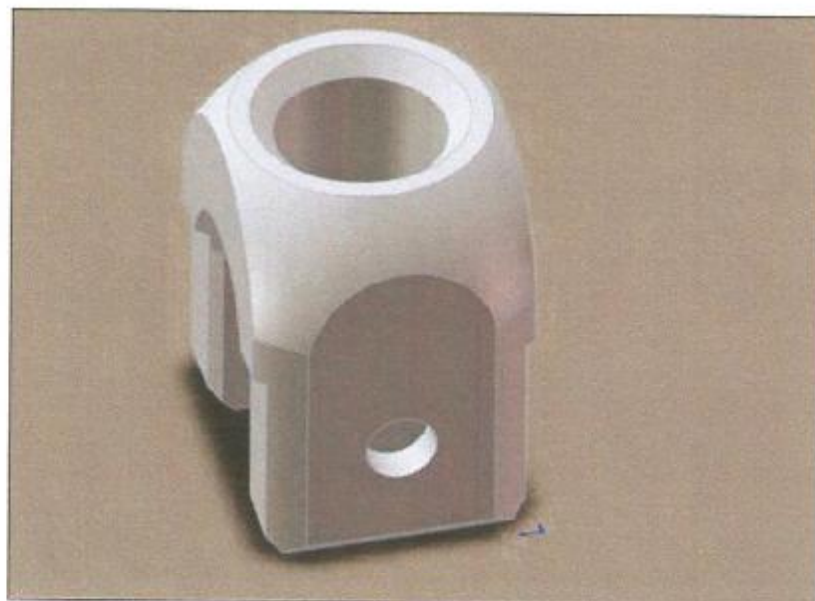

Fig. 7 - U-Channel

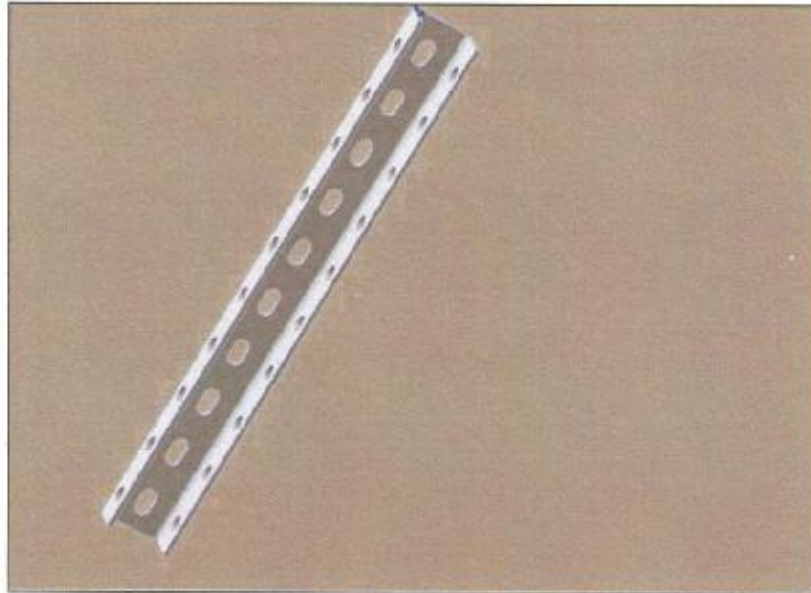

Fig. 8 - Bracket for canal

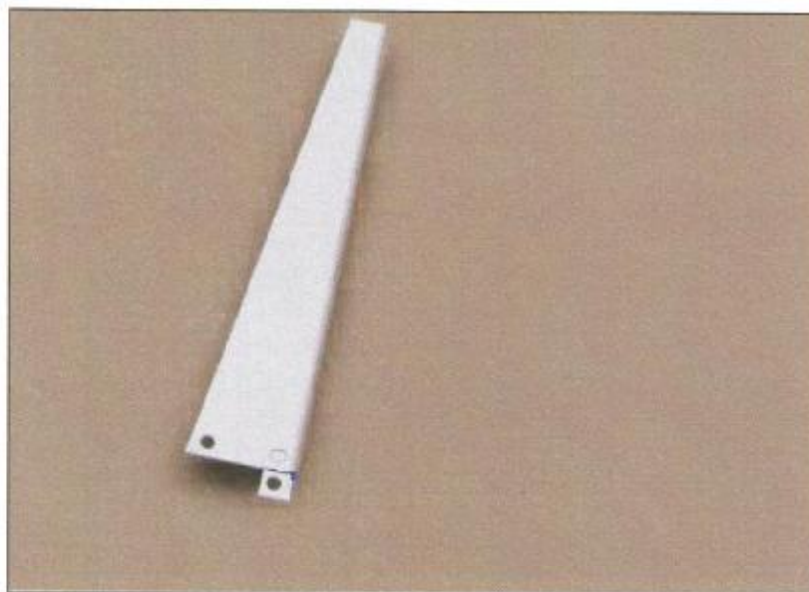

Fig. 9 - Heavy U-Channel

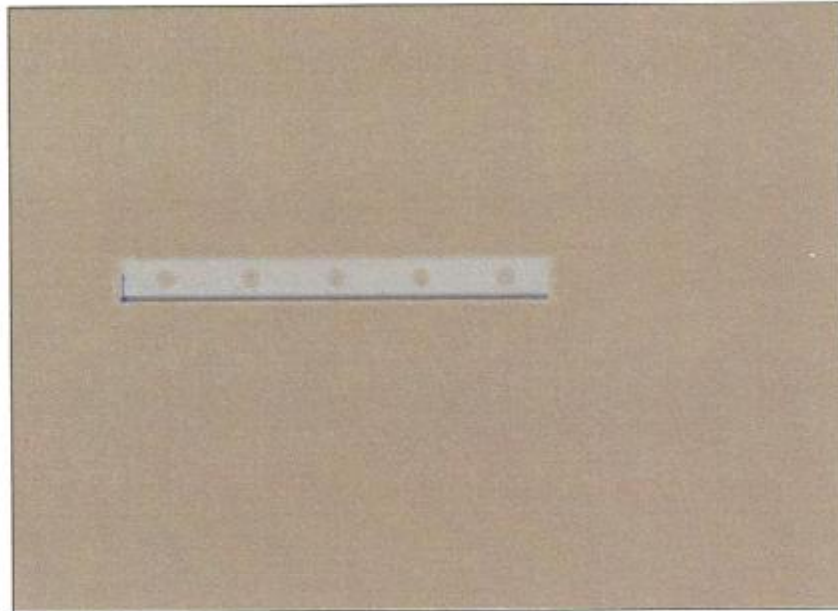

Fig. 10 - Adjustable angle base

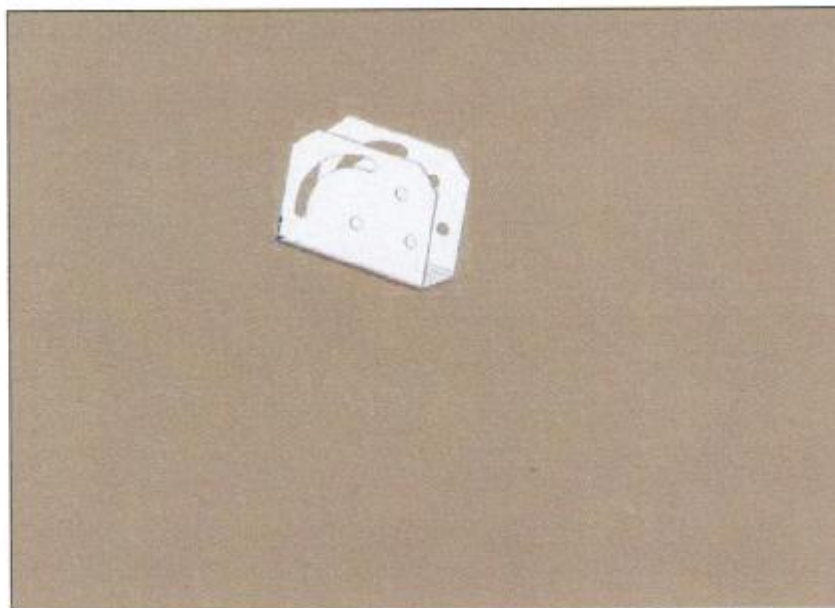

Fig. 11 - C-channel blots

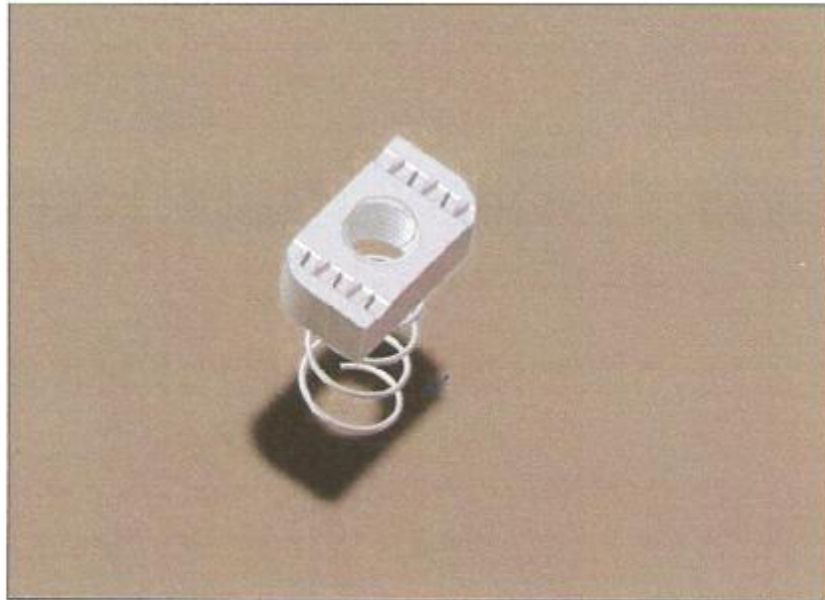
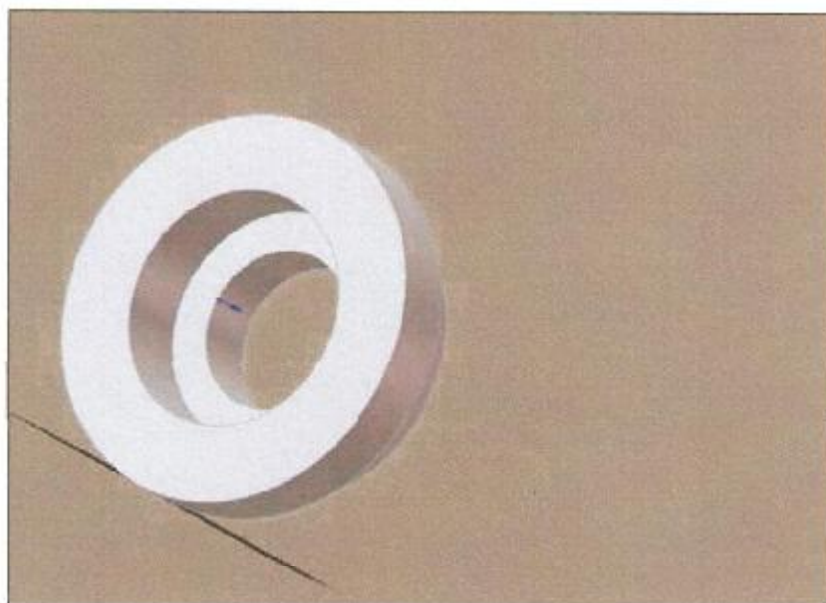

Fig. 12 - Nut 6 Mm





ISO 9001:2000
Reg. 7977-1

Fig. 13 - Insulator

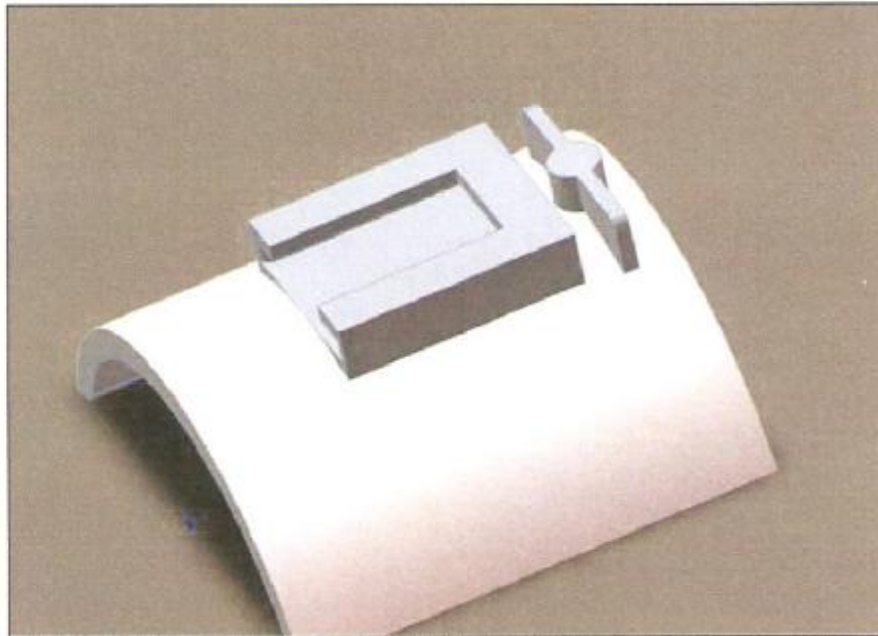

Fig. 14 - Nut -C Channel

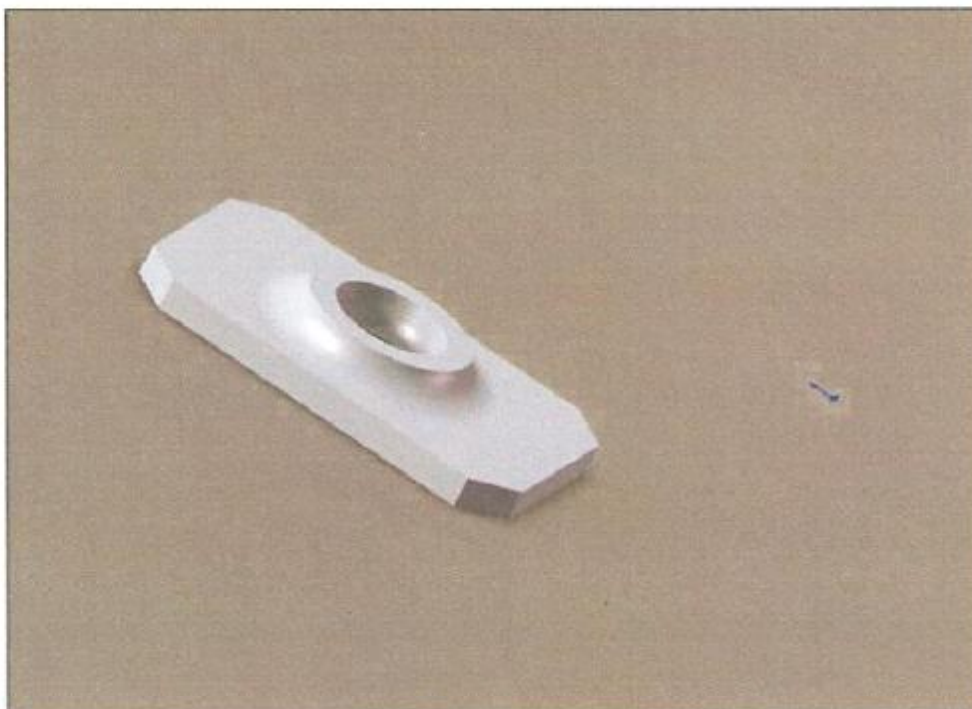

Fig. 15 - Bolt

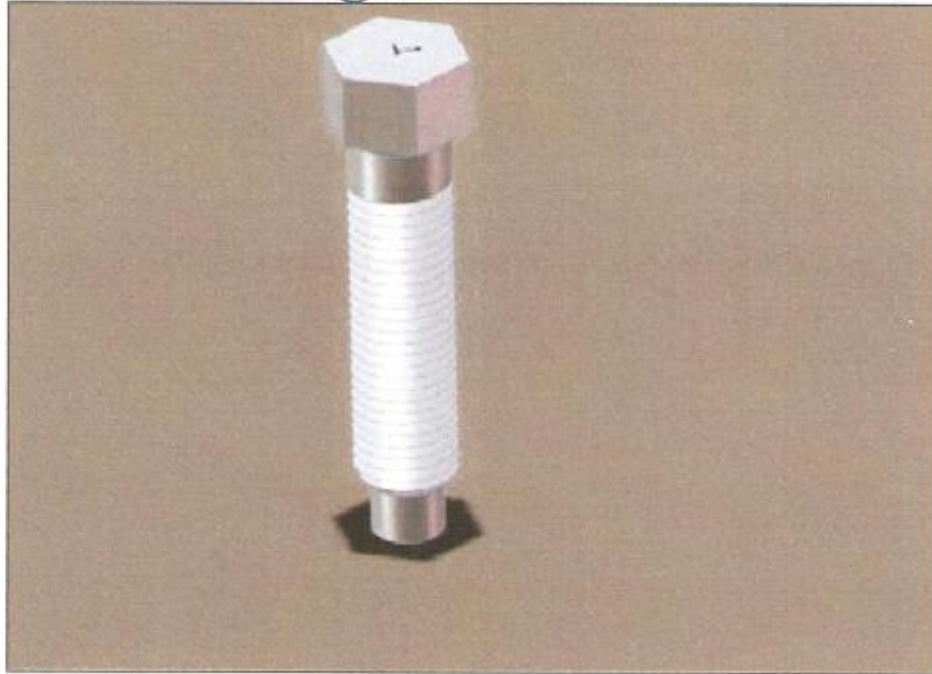
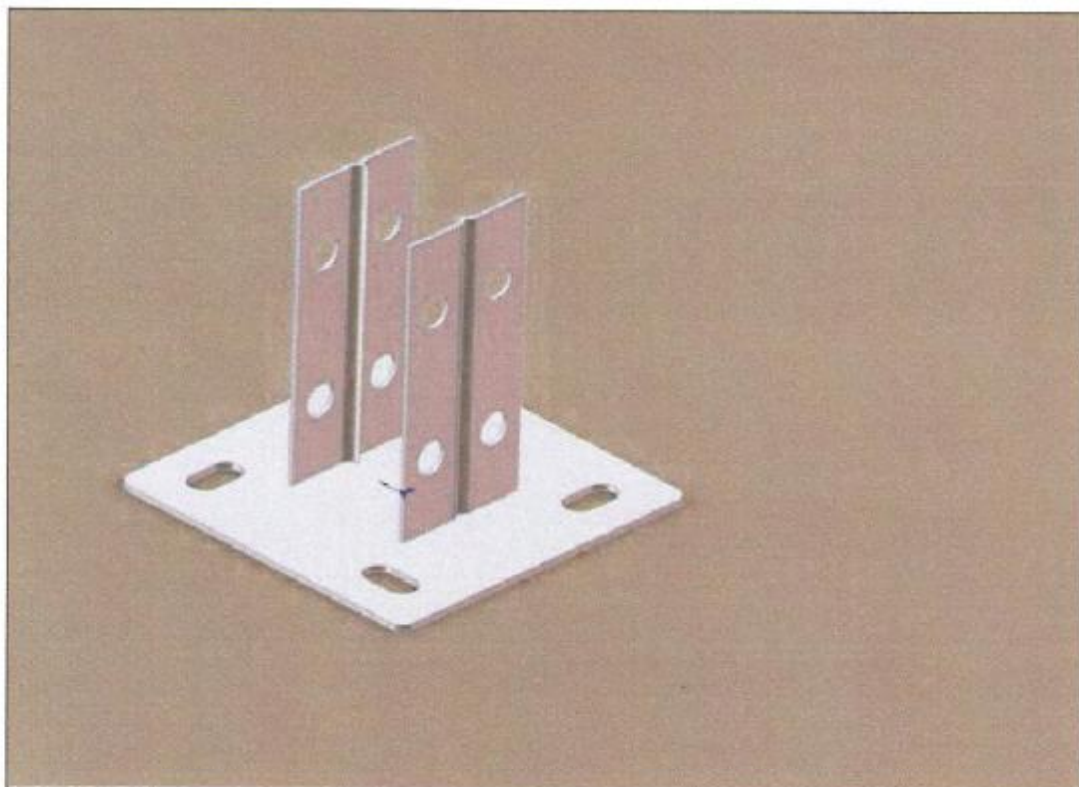

Fig. 16 - Ceiling mounting double base





ISO 9001:2000
Reg. 7977-1

Fig. 17 - Ceiling mounting single base

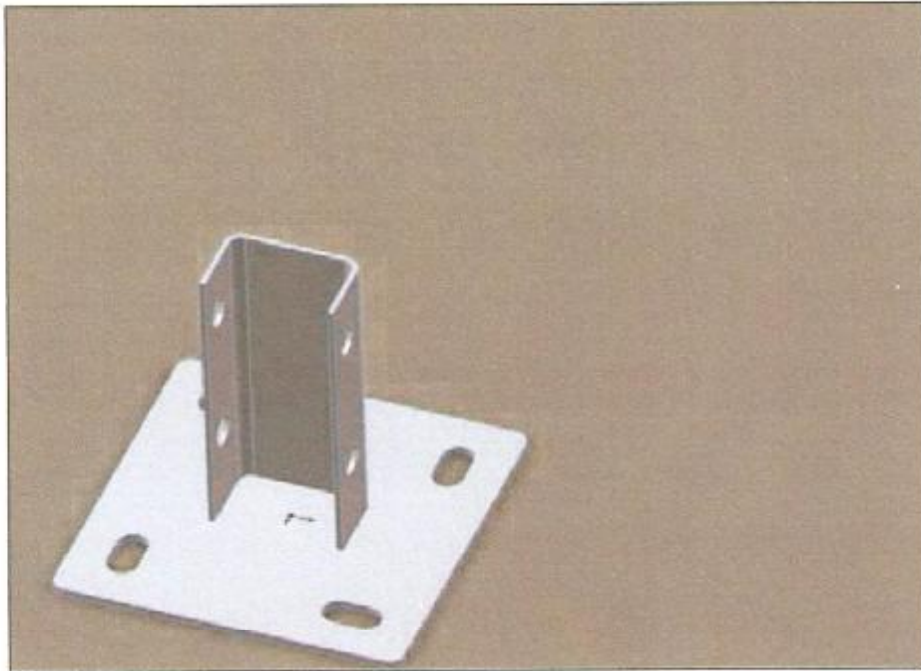

Fig. 18 - Angle

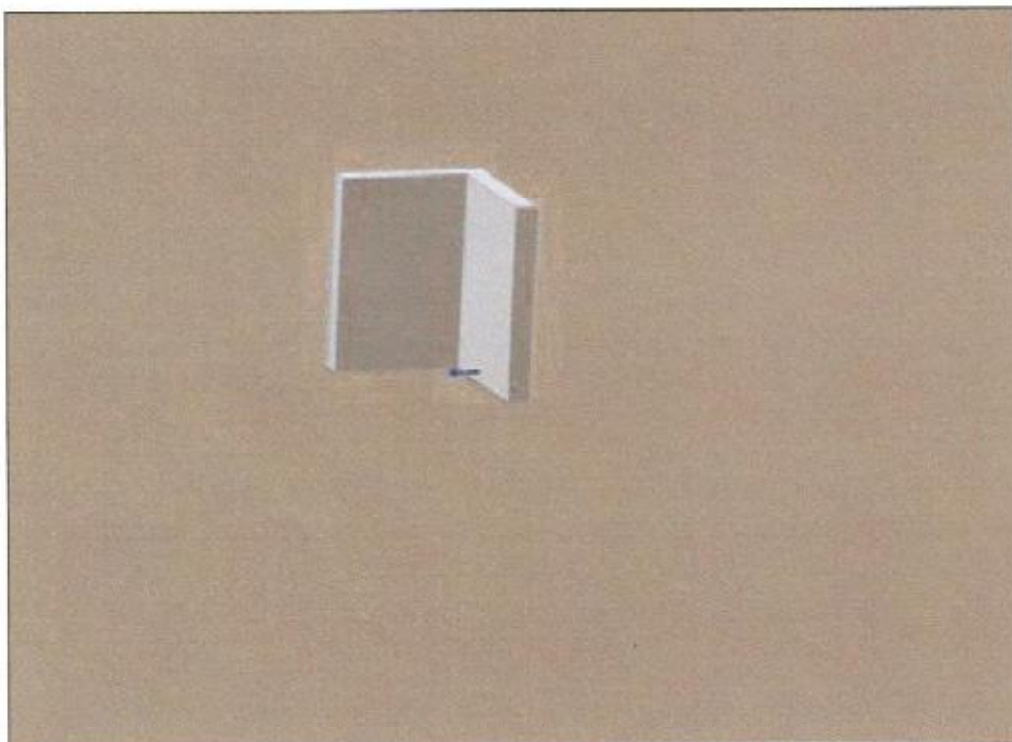

Fig. 19 - Threaded Rod

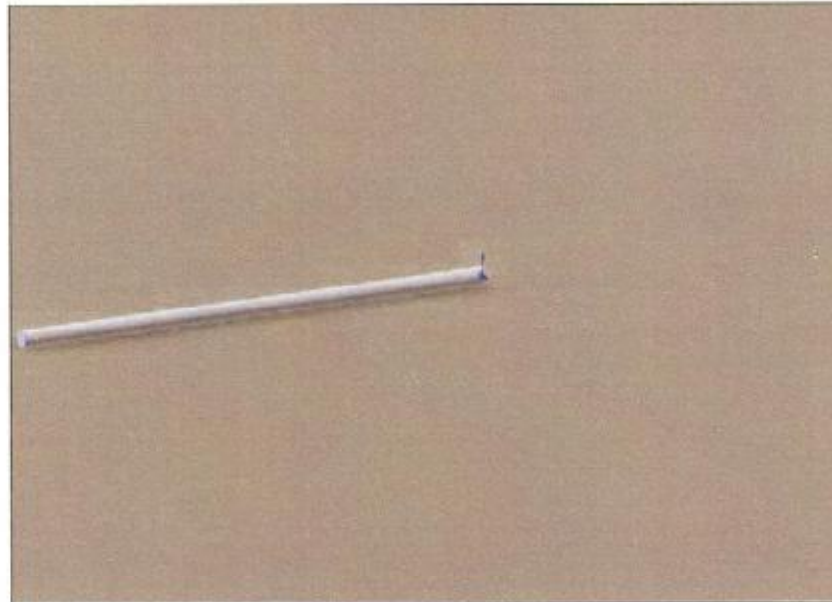
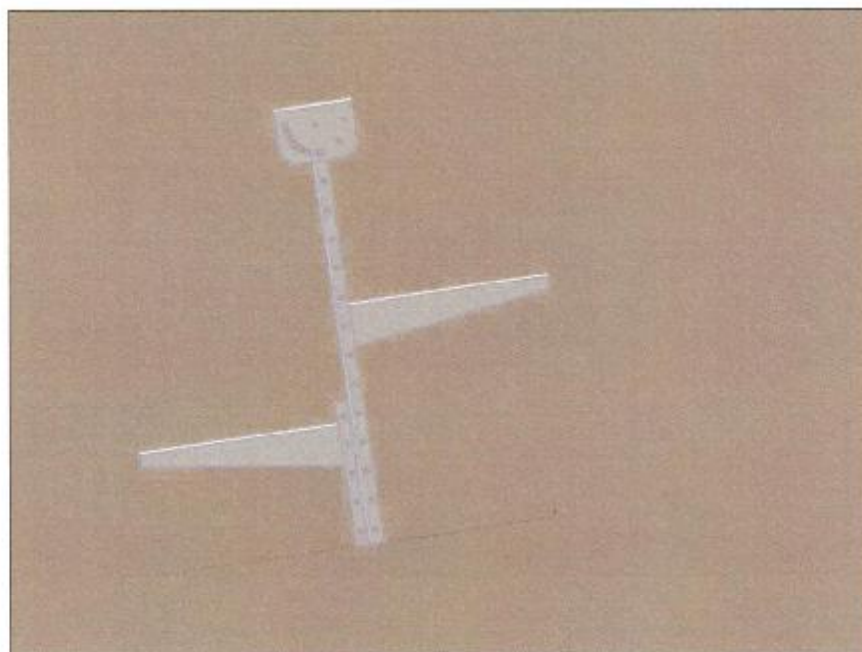

Fig. 20 - Ceiling mounting with limit height





ISO 9001:2000
Reg. 7977-1

Fig. 21 - Ceiling Support (From one side)

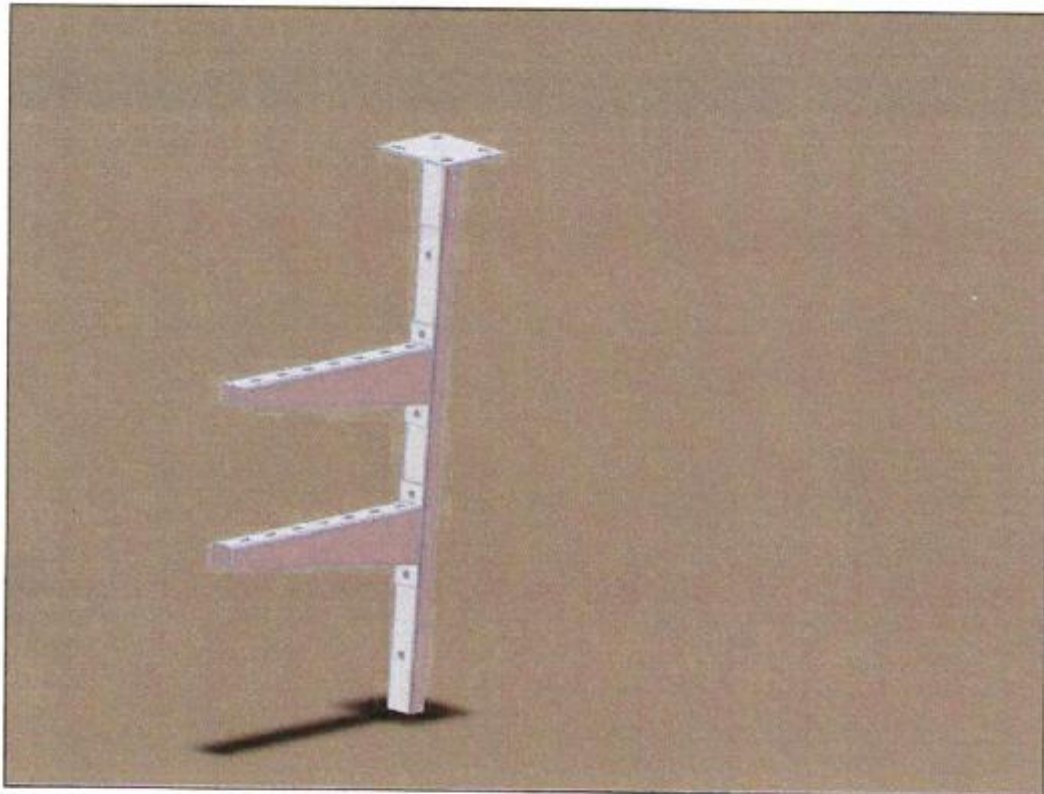



ISO 9001:2000
Reg. 7977-1

Annex B – Drawings (supporting system)

Supporting systems of Assured Protection Vista

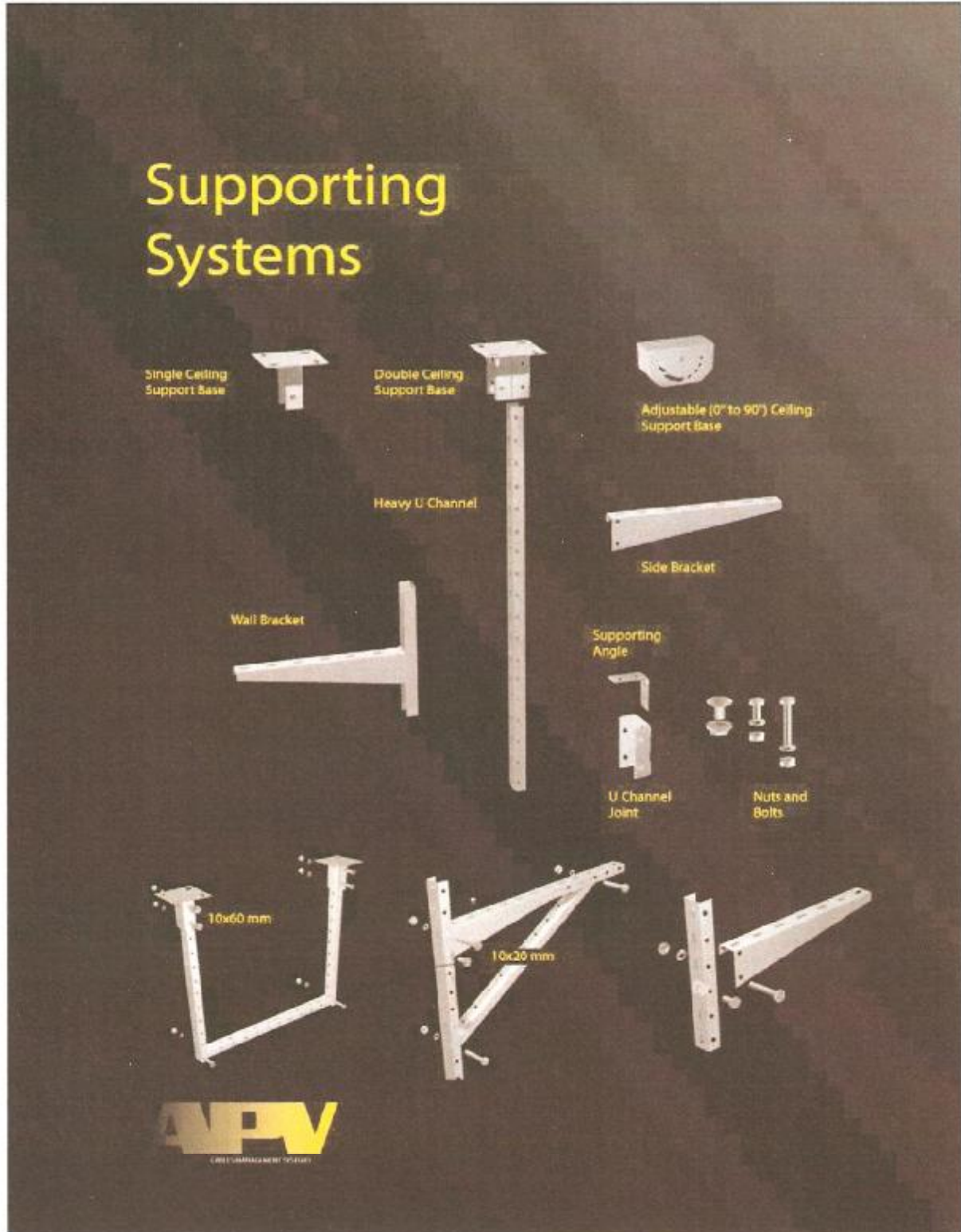



ISO 9001:2000
Reg. 7977-1

Annex C – Design Instructions

Design Instructions for Cables Management Systems by Assured Protection Vista

Design Instructions for Cables Management Systems

Design Instruction for cable trays using must be strictly read before setting, if there is any question to ask please contact immediately the company.

1. The person in charge to settle the cable trays should be aware of its settling and ever do any personal effort without referring to the company.
2. Always check the content before starting eh settlement to make sure of the components of cable trays & its accessories. In case of any shortage please contact the company.
3. Should use the original components required for assembling (bolts, nuts, joints ...etc) don't do any personal effort to cover any shortage and if any please contact immediately the company.
4. Never settle the cable trays in the non safe areas, taking into consideration the Design measures like (its falling on people or material breakable).
5. Wearing personal design clothes (gloves, glasses, hats, shoes) when settling.
6. Make sure there is no defect or deformity after settling.
7. Never put extra weight to the specified weight of the cable trays.
8. Use only the equipments used for cable trays settings and make sure of its design.
9. Use safe ladders for the high walls & roofs.

Site Storage:

Site storage must be safe, clean, and not on the pedestrian cross or cars cross or under the construction sites operation (paint, sprinkle, mud, welding) Accessories storing in a closed area (nails, bolts, joints) to not be subject to waste.

Cut & Settling:

1. Take the exact measures before start cutting, and determine the line of the cable trays from the beginning till the end.
2. Use new & sharp cut equipments, make the angle rectangular to avoid any deformation at the point of joint, chill & remove any nub (**) from trays after cutting stage.
3. Set up the side & floor joints inside the cable trays where the bolts are put inside and the nuts outside (nuts measure totally suitable to bolts measure).
4. Make sure the wall, floor & roof trays are fixed perfectly before fixing the cables taking into consideration the distance between the trays must not exceed one meter and half.
5. If there are more than one shelf for cable trays the reparative distance between each shelf and another must be not less than 125 cm.



Installation Instructions Of Cables Trays ((supports)) Ceiling , Wall , Floor:

Ceiling Support:

The roof to be fixed by a wedge (plastic or metal) according to the carrying schedule. Bolts required for the roof trays needs to be 2" which is the lowest and has to be fixed with the suitable nuts according to cement thickness in the buildings. If there are many shelf to settle, the distance between each roof tray and the other needs To be 1 meter. Taking into consideration angles bends where it has to be settled with Special trays its measuring started from 0 till 90.

Ceiling Support Using:

- 0 Metallic cable trays.
- 0 Ladder metallic cable trays .

Virtues & Advantages:

1. For curves & hard surfaces in the roofs.
2. For bolts and basis on which its fixed with all metric lengths.
3. Basis can also be fixed outside the curves by 5 cm.

Wall Support:

A wall tray can be fixed by a wedge (plastic or metal) according to the carrying schedules Required. If there are more than one shelf to settle the distance between each tray and another Must be 1.25 cm taking into consideration the angles where it has to be settled in special Trays measuring started from 0 to 90 with all what the bends and angles in constructions Need.

Wall Support Using:

- 0 Paths for cables & Cable Trays.

Virtues & Advantages:

1. The quick and simple carrying and reduce settling time (with accessories made especially for metallic cable trays & Ladders).
2. Its forbidden to fix aside (grave the walls and reduce the stickers to be put on).



ISO 9001:2000
Reg. 7977-1

CONSULTANTS EUROPE bv

TECHNICAL & LEGAL EXPERTS

Floor Support:

Floor trays to be fixed by a bolts for special metallic trays and has to be set by joining Between each tray and another through (Stapler – Clump)

Floor Support Using:

- 0 Fix the cable trays on buildings & projects ground.
- 0 Fix the trays on buildings & projects trays.
- 0 Under the metaphoric ground.

Virtues & Advantages:

1. No need to dig or weld the trays.
2. Can be adjusted at any time.
3. Possibility to bundle more than one shelf for settling, thus the distance between Each tray and another must be 1.50 cm taking into consideration the bending and Angles where it has to be settled by special trays measuring started from 0 to 90 Also as the buildings & projects angles and bend needs.



ISO 9001:2000
Reg. 7977-1

Annex D – Contact Information

CONTACT INFORMATION

Contact information Assured Protection Vista A.P.V.

MHD.Mazen Al Malat
General Manager

PO Box: Sbeneh76

Damascus - Syria

Tel: +963 11 8229201 \ 5

Fax: +963 11 8229206

Mobile: +963 933338515

Web: www.apv-group.com

E-Mail: info@apv-group.com \ apv.mazen@yahoo.com

Contact information Consultants Europe.

Mr. Serge Koumatchev
Technical and Legal Expert

PO Box 5047

Weesp, The Netherlands

Nieuwstad 100, 1381 CE

Tel: +31 294 4833 55

Fax: +31 294 4146 87

Web: www.ce-marking.nl

E-Mail G.E. : info@ce-marking.nl

E-Mail: technical.and.legal@ce-marking.nl



ISO 9001:2000
Reg. 7977-1

CONSULTANTS EUROPE bv

TECHNICAL & LEGAL EXPERTS

Annex E – General Product and Manufacturer Information

INFORMATION FROM THE MANUFACTURER,

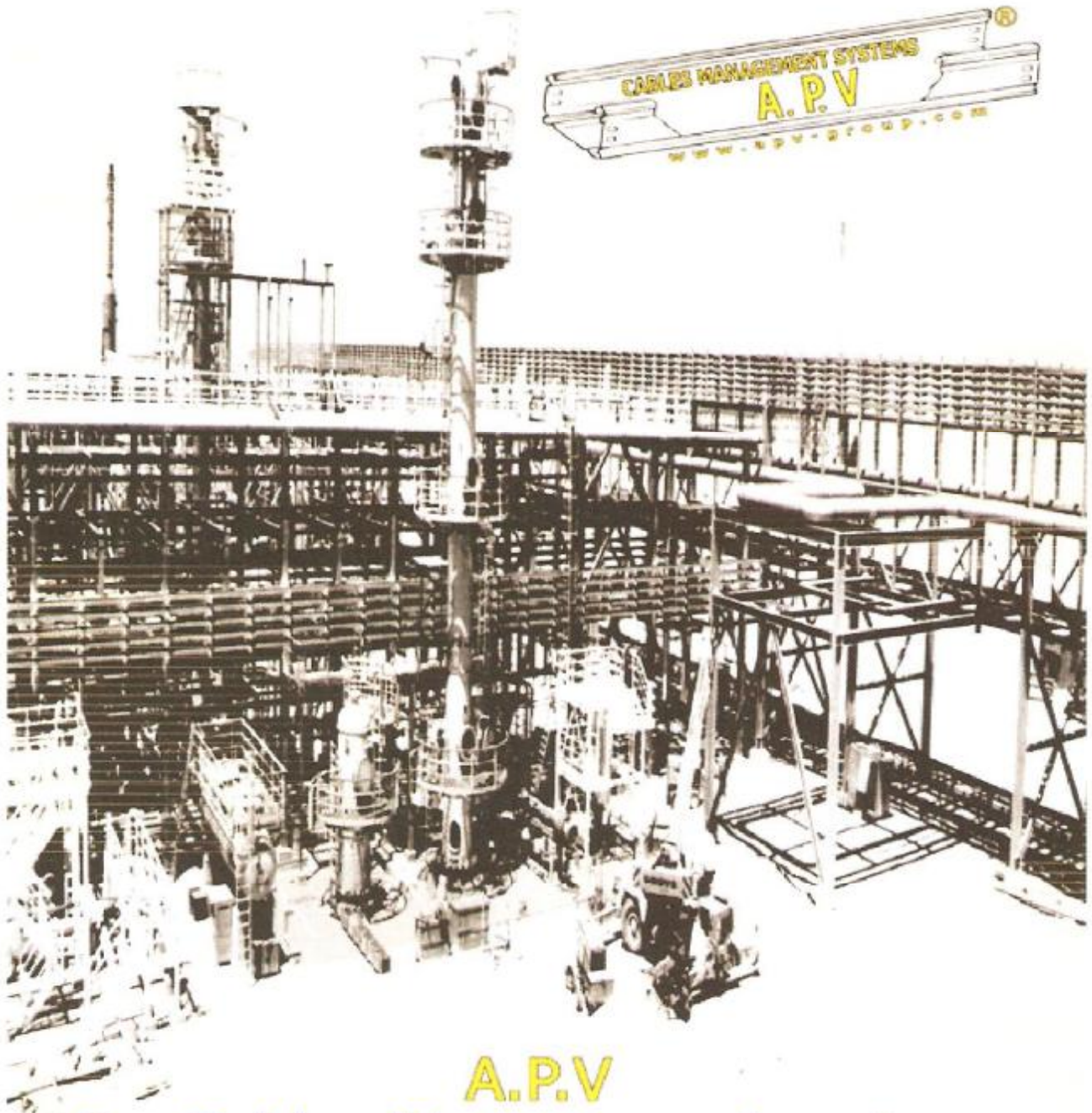

A.P.V for Cables Management systems

2009





ISO 9001:2000
Reg. 7977-1

A.P.V for Cables Management Systems

لأنظمة إدارة الكابلات

مجموعة منتجات وأجهزة من صناعة الشركة المصنعة من سنة 1976 إلى سنة 2016



1. Perforated Cable Trays "PCT" :

This tow Systems are available in 3 different heights 50,75,100mm with widths 50,75,100, 150,200,300,400,500,600,700,800,900 mm and the thicknesses are depending on the tray dimensions.

These kinds of Systems contain strengthening ribs to reduce the thickness of iron therefore the tray is lighter which will help in the installation process (more quick & easy) with the stiffer profile.

"Curved Edges" which are applied in all of the Trays designs are for protecting against cuts and scratches. Beside other features which are displayed in the Catalogue attached.

2. Solid bottom Cable Tray "SCT" :



3. Cable Ladder System :

This System is available in 3 different heights 50,75,100mm with widths 150,200,300,400,500,600,700,800,900,1000mm. with 3 different types :

- 1. Light
- 2. Medium
- 3. Heavy

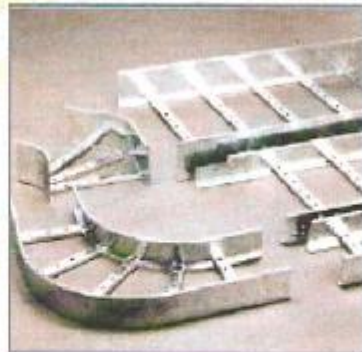

All for this system accessories are available with one of two Internal bending angle 125mm and 300mm.

4. Cable Tray Supports System :

The Support Systems cover various kinds of Brackets, including ceiling, wall and earth-bom supports.





ISO 9001:2000
Reg. 7977-1

A.P.V. for Cables Management Systems الأنظمة لإدارة الكابلات

شركة صيدان للصناعات والتجارة مقرها: 101 شارع 15، دمشق، سورية



In addition, A.P.V. produce communication towers:

- Telecommunication towers in all different shapes and heights :
 - 1 . Mast / 4.50 m /
 - 2 . Mast / 5 m /
 - 3 . Mast / 6 m /
 - 4 . Mast / 9 m /
- Telecommunication towers with tree shape .
- Equipments of communication shelters .
- * The final products which are available contain :
 - Sandzimir galvanizing (Thickness of galvanizing is: ST42) .
 - Power painting.
 - Aluminum .
 - Electrolytic galvanizing .
 - Stainless steel.
 - Hot Dip Galvanizing after manufacturing according to specification BS EN 1461 for minimum protection coating (thickness & weight).
- * Specifications: solid, perforated, ladder systems' specifications are according to the VDE and IEC.





ISO 9001:2000
Reg. 7977-1

CONSULTANTS EUROPE bv

TECHNICAL & LEGAL EXPERTS

A.P.V. for Cables Management Systems
لأنظمة إدارة الكابلات
 شركة محمد باسول و محمد مانع الحايك للتجارة الدولية - عمان - الأردن - 11144



* The following table shows useful guidelines for the selection of the best

GUIDELINE FOR CABLE TRAY SELECTION					
ENVIRONMENT	SENDIZIMIR	PAINTED	HOT DIP GALVANIZED AFTER MANUFACTURE	AISI 304 STAINLESS STEEL	AISI 316 L STAINLESS STEEL
STANDARD INTERNAL ENVIRONMENT	VERY GOOD	VERY GOOD	UNNECESSARY	UNNECESSARY	UNNECESSARY
STANDARD EXTERNAL ENVIRONMENT	GOOD	VERY GOOD	GOOD	NOT RECOMMENDED	NOT RECOMMENDED
FOOD-INDUSTRY LIKE ENVIRONMENT	GOOD	VERY GOOD	NOT RECOMMENDED	GOOD	UNNECESSARY
MARINE TYPE ENVIRONMENT	NOT RECOMMENDED	GOOD	GOOD	VERY GOOD	VERY GOOD
ACID TYPE ENVIRONMENT	NOT RECOMMENDED	GOOD	NOT RECOMMENDED	GOOD	VERY GOOD
ALKALINE TYPE ENVIRONMENT	NOT RECOMMENDED	GOOD	NOT RECOMMENDED	GOOD	VERY GOOD
HALOGEN TYPE ENVIRONMENT	NOT RECOMMENDED	GOOD	NOT RECOMMENDED	GOOD	GOOD
ABRASIVE TYPE ENVIRONMENT	NOT RECOMMENDED	GOOD	GOOD	NOT RECOMMENDED	NOT RECOMMENDED





ISO 9001:2000
Reg. 7977-1

A.P.V. for Cables Management Systems

الأنظمة لإدارة الكابلات

شركة أ. ب. في. ب. لمجموعة من منتجات إدارة الكابلات المتخصصة في سوريا ولبنان
TRAP: 1-800-11-822 92 01/5



The Quality that A.P.V. carries along with can stand strongly in both the local and the International markets.

The picture below displays the features that A.P.V. Cable Tray System provides:

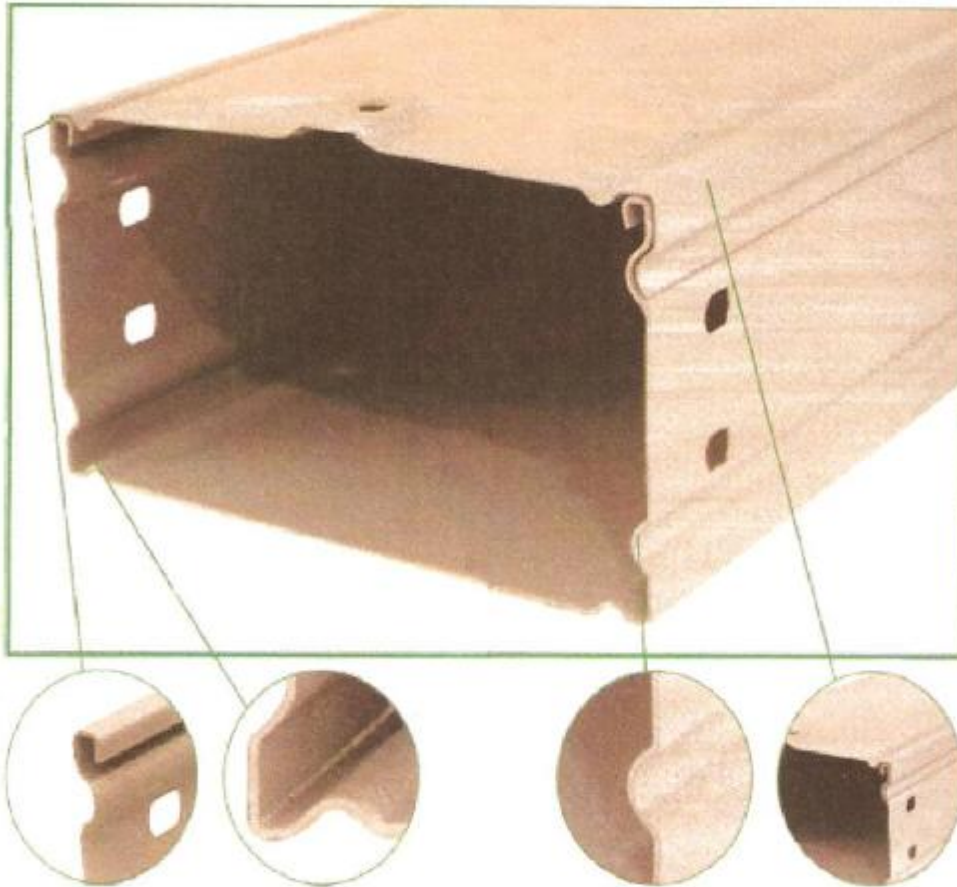

Curved Edge

- For protection of cables and hands against cuts.
- For stiffer profile .

Bottom Ribs

- For protection of cables against condensation.
- For stiffer profile .

Side Ribs

- For placing the tray on the bracket without drilling.
- For stiffer profile .
- For fixed side joint .

Cover

- Self-Locking on the tray.
- Designed to house the electrical connector , and to provide more stiffness .





ISO 9001:2000
Reg. 7977-1

CONSULTANTS EUROPE bv

TECHNICAL & LEGAL EXPERTS

A.P.V. for Cables Management Systems

لأنظمة إدارة الكابلات

مجموعة منتجات وأجهزة وبرمجيات إدارة الكابلات المتخصصة من نوع: A.P.V. (A.P.V. 168A)



Our clients:

Some of our client's locations:

- ➔ Italy.
- ➔ Jordan.
- ➔ Lebanon.
- ➔ Kingdom of Saudi Arabia.
- ➔ UAE.
- ➔ Kuwait.
- ➔ Canalelec Company \ Italy
- ➔ Harb Electric \ Lebanon.

Some of our clients:

- ➔ Oil & Gas Co.
 - Conoco Co. "Oil & Gas Projects"
 - Govmor Co. "Oil & Gas Projects"
 - Ansaldo Co. "Oil & Gas Projects"
 - National Petroleum Co. \ Jordan
 - Al-Darrak Co.
 - Sroy Trans Gas Co.
 - Petrocanda Co.
 - Hisco.
 - AL-Tabyaeh Gas Co.
- ➔ Mobile: Co.
 - Fast Link Co. "Mobile Comm. Co. in Jordan"
 - Syriatel Co. "Mobile Comm. Co. in Syria"
 - M.T.N Co. "Mobile Comm. Co. in Syria"
- ➔ Mall:
 - Makkah Mall \ Amman - Jordan
 - Nouman Mall \ Amman - Jordan
 - Town Center \ Damascus - Syria
 - Sham City Center \ Damascus - Syria
 - Damasquino Mall \ Damascus - Syria
 - Al-Manzbeh Mall \ Aleppo - Syria
 - New Town Mall \ Aleppo - Syria
- ➔ Banks:
 - Central Bank \ Damascus - Syria
 - Branch 13 Bank \ Damascus - Syria





ISO 9001:2000
Reg. 7977-1

A.P.V. for Cables Management Systems

الأنظمة لإدارة الكابلات

تصميم وتركيب أنظمة إدارة الكابلات الصناعية والمنزلية



- Beano Bank \ Damascus – Syria
- Syria & Over Seas Bank \ Damascus – Syria
- Syria & Gulf Bank \ Damascus – Syria
- Real Estate Bank \ Damascus – Syria
- Islamic Bank \ Damascus – Syria
- Arabic Bank \ Damascus – Syria
- Islamic Sham Bank \ Aleppo – Syria
- ➔ Hotels:
 - Sheraton Hotel \ Aleppo & Saydnata – Syria
 - Carleton Hotel \ Aleppo – Syria
 - Coral Jolia & Douzza Hotel \ Aleppo – Syria
 - New Vandoum Hotel \ Aleppo – Syria
 - Zebdel Resort \ Homs – Syria
- ➔ Other Projects:
 - AL-Halemoon Co. \ Kingdom of Saudi Arabia
 - AL-Boniam Group \ Beirut – Lebanon
 - Queen Ranya Hospital Exposition Project \ Jordan
 - Al-Basheer Hospital Exposition Project \ Jordan
 - Aqua Park \ Jordan
 - Dead Sea Panorama \ Jordan
 - Jordanian Parliament
 - Himisho For Metals \ Lattakia – Syria
 - Technical Group
 - Syrian Cables Co.
 - El-Sham Cables Co.
 - Damascus International AirPort
 - Universal Company for Construction
 - Syfco Company for Medicine
 - Katakot Company for Food Industries
 - Technical Group Co. as a subcontractor for Bin Laden Airport construction
 - Al Basal Hospital for heart disease & surgeries
 - Palm Village
 - Ammora Group.
 - Unipharma Company for Medicine
 - Crystal City
 - Areej Electro mechanic
 - Al-Maracim Co. for Bin Laden Project





ISO 9001:2000
Reg. 7977-1

CONSULTANTS EUROPE bv

TECHNICAL & LEGAL EXPERTS

A.P.V for Cables Management Systems لأنظمة إدارة الكابلات

شركة سورية باريوت و سورية بارزة الباط للتجارة من سوريا - سورية - 11190 - حلب - 1616



- Al-Murdiny Hospital \ Aleppo - Syria
- Unvrerity Hospital \ Lattakia & Aleppo - Syria
- Shamseen Bakeries \ Damascus & Aleppo - Syria
- Free zone \ Lattakia - Syria
- Al-Ma'amoun University \ Kamohle - Syria
- Syria Mica Group \ Aleppo - Syria
- Jubilees Advanced System \ Amman - Jordan
- Middle East for Contracting
- Balkees Factory for Ceramic



And much more





ISO 9001:2000
Reg. 7977-1

CERTIFICATE **TUV NORD**

Management system as per
EN ISO 9001 : 2000

In accordance with TÜV NORD CERT procedures, it is hereby certified that

ASSURED PROTECTION VISTA
A.P.V For Cables Management Systems
P.O. Box: Sbeneh 76,
Daraa Old St.,
Damascus, Syria



applies a management system in line with the above standard for the following scope

Manufacturing of cables management systems; Solid systems, trunking systems, perforated systems, ladder-type systems, flexible system.

Certificate Registration No. 44 100 081568
Audit Report No. 3503 6024

Valid until 2011-09-25

G. Bräutigam

Certification Body
at TÜV NORD CERT GmbH

Essen, 2008-09-20

This certification was conducted in accordance with the TÜV NORD CERT auditing and certification procedures and is subject to regular surveillance audits.

TÜV NORD CERT GmbH

Langemarktstrasse 20

45141 Essen

www.tuev-nord-cert.com



TGA-ZM 07-08-00



ISO 9001:2000
Reg. 7977-1

CASE STUDY

STRENGTH CALCULATION OF CABLE TRAY SECTION (Resistance to Bending in Horizontal Direction)

Moment of inertia, also called mass moment of inertia or the angular mass, it is a measure of an object's resistance to changes in its rotation rate. It is the rotational analog of mass. That is, it is the inertia of a rigid rotating body with respect to its rotation.

Moment of inertia was introduced by Euler in his book a Theoria motus corporum solidorum seu rigidorum in 1730. In this book, he discussed at length moment of inertia and many concepts, such as principal axis of inertia, related to the moment of inertia.

The Area Moment Of Inertia of a beams cross-sectional area measures the beams ability to resist bending. **The larger the Moment of Inertia the less the beam will bend.** The moment of inertia is a geometrical property of a beam and depends on a reference axis. The smallest Moment of Inertia about any axis passes through the centroid. The following are the mathematical equations to calculate the Moment of Inertia:

Moment of inertia:

$$M_x = \sum \frac{b(d)^3}{12}$$

[CABLE TRAY SECTION (300mm Wide x 50mm High)]

CASE (A) Regular Cable tray Section

Moment of Inertia:

$$M_x = \sum \frac{b(d)^3}{12} = \frac{300 \times (2)^3}{12} + \frac{2 \times (2 \times (50)^3)}{12} = \frac{502400}{12} = 41867$$

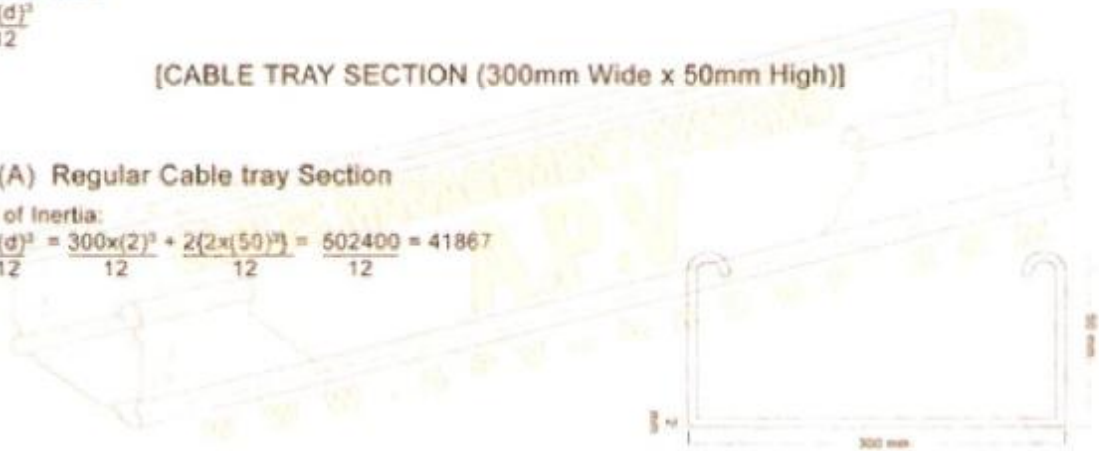

CASE (B) A.P.V Cable tray Section

Moment of Inertia:

$$M_x = \sum \frac{b(d)^3}{12} = \frac{[300 + 2(5-2)] \times (1.25)^3}{12} + \frac{2 \{ 1.25 \times (50 + 2(5-2) + 3 + 4)^3 \}}{12}$$
$$= \frac{598}{12} + \frac{625118}{12} = \frac{625716}{12} = 52143$$



Conclusion:

$$52143 > 41867$$

Since the larger the moment of inertia the less the beam will bend, so case (B), A.P.V Cable tray section with 1.25 mm thickness shows more bending resistance than the case (A), regular cable tray section with 2 mm thickness.





ISO 9001:2000
Reg. 7977-1

CONSULTANTS EUROPE bv

TECHNICAL & LEGAL EXPERTS

A.P.V for Cables Management Systems
 لأنظمة إدارة الكابلات
 دمشق - سورية | دمشق - سورية | دمشق - سورية | دمشق - سورية | دمشق - سورية

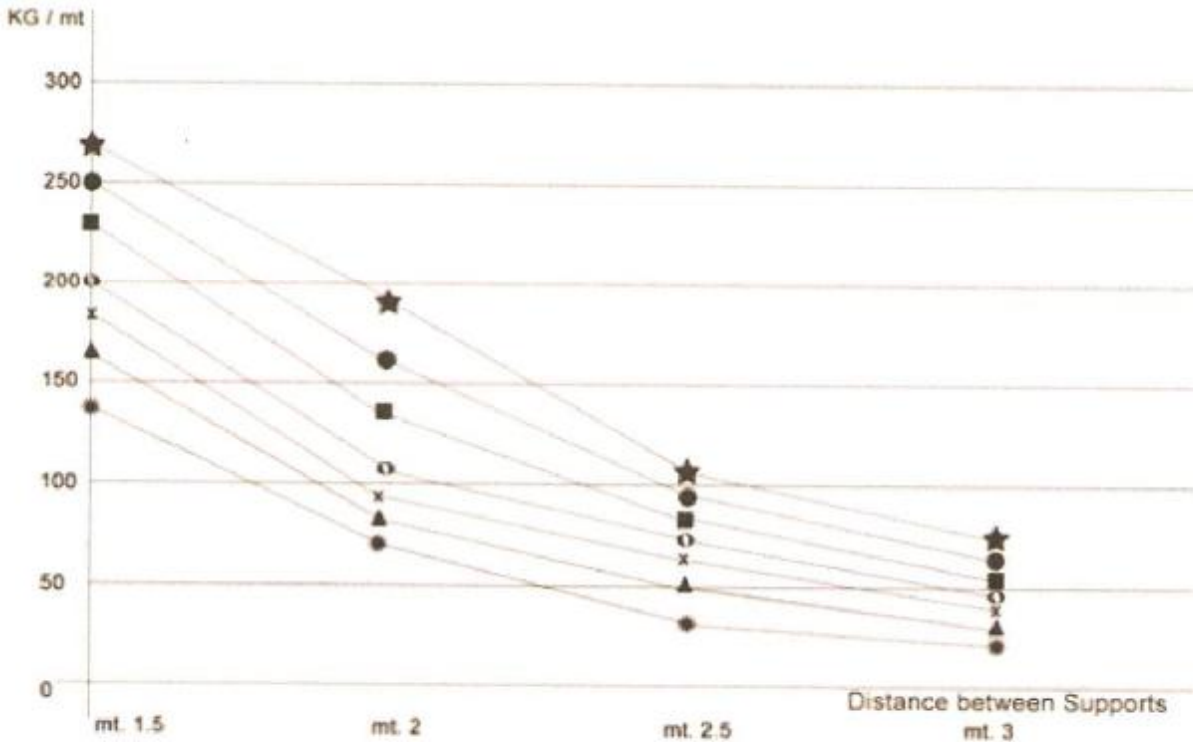

Legend	
★	075 500
●	075 400
■	075 300
○	075 200
x	075 150
▲	075 100
●	075 075

Assured Protection Viste A.P.V for Cables Management Systems Syria, Damascus, Dama Old
 St. Allendeh Exit, P.O.Box: Seneh75
 Tel: +963 11 822 92 01/5
 Fax: +963 11 822 92 06
 e-mail: info@apv-group.com Web: www.apv-group.com



LOADING GRAPHS

Strengthened CABLE TRAYS



LOAD CAPACITY

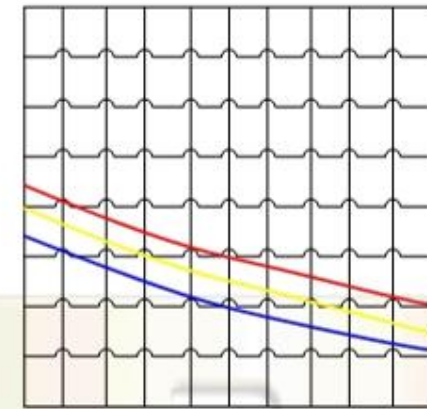
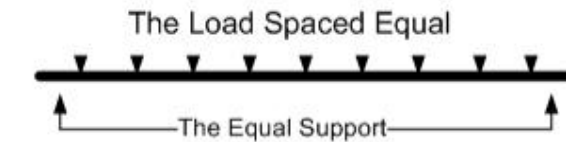
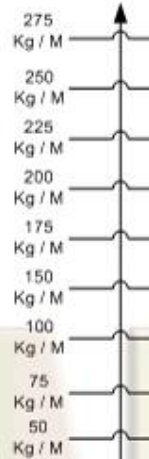

Thickness

- 0.9 mm
- 1 mm
- 1.2 mm

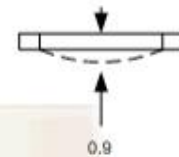

Safety Factor = 1.7

SUPPORT SPAN

Strengthened CABLE TRAYS



LOAD CAPACITY

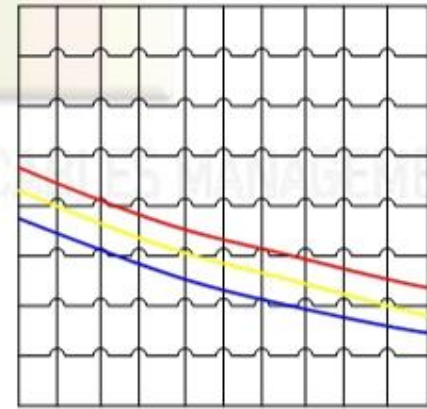
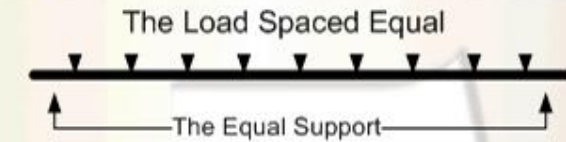
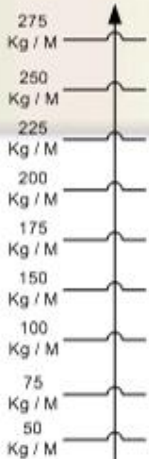

Thickness

- 0.9 mm
- 1 mm
- 1.2 mm

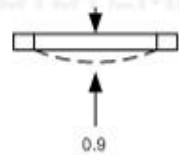

Safety Factor = 1.7

SUPPORT SPAN



LOADING GRAPHS

Strengthened
CABLE TRAYS

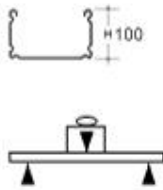

LOAD CAPACITY

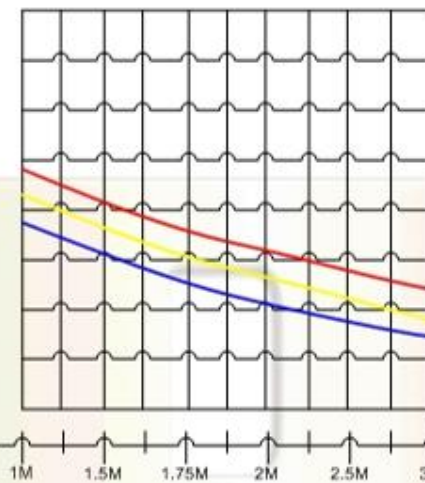
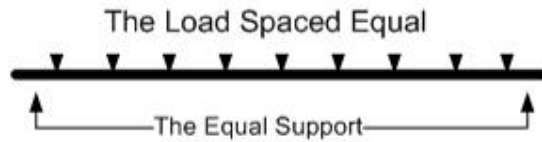
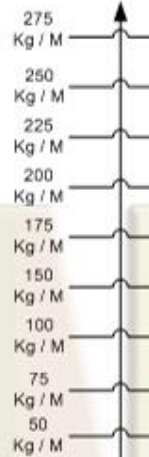

Thickness

- 0.9 mm
- 1 mm
- 1.2 mm

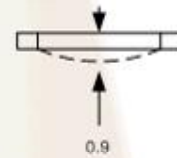

Safety Factor = 1.7

SUPPORT SPAN

CABLES MANAGEMENT SYSTEMS



LOADING GRAPHS

Strengthened
CABLE LADDER

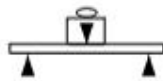

LOAD CAPACITY

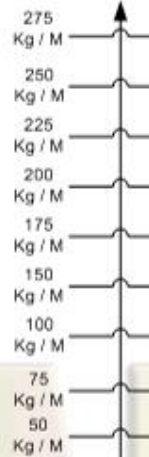

The Load Spaced Equal

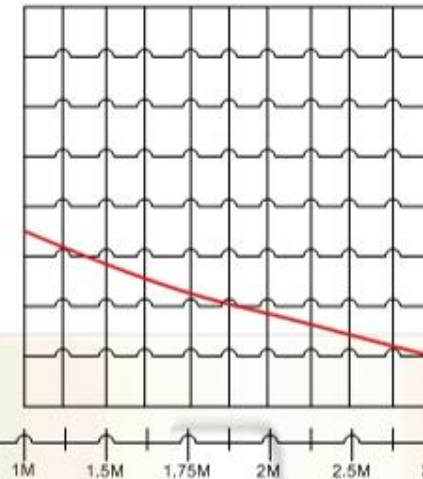

SUPPORT SPAN

Thickness

1.5 mm

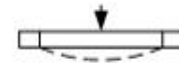

0.6

Safety Factor = 1.7

Strengthened
CABLE LADDER



LOAD CAPACITY

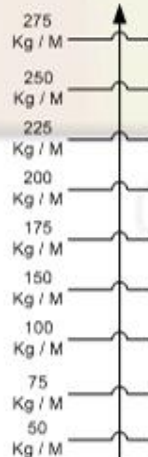

The Load Spaced Equal

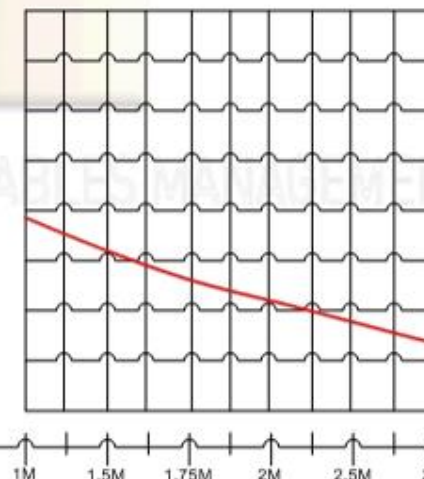

SUPPORT SPAN

Thickness

1.5 mm



0.6

Safety Factor = 1.7



LOADING GRAPHS

Strengthened
CABLE LADDER



LOAD CAPACITY

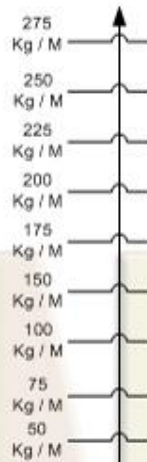

The Load Spaced Equal

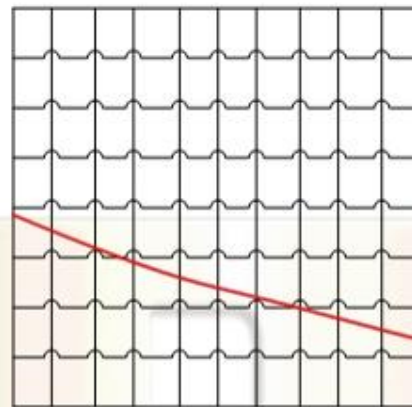

Thickness

1.5 mm

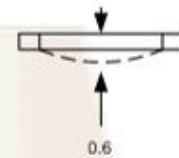

Safety Factor = 1.7

SUPPORT SPAN

CABLES MANAGEMENT SYSTEMS



LOADING GRAPHS

Strengthened
CABLE LADDER

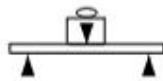

LOAD CAPACITY

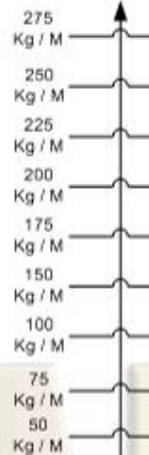

The Load Spaced Equal

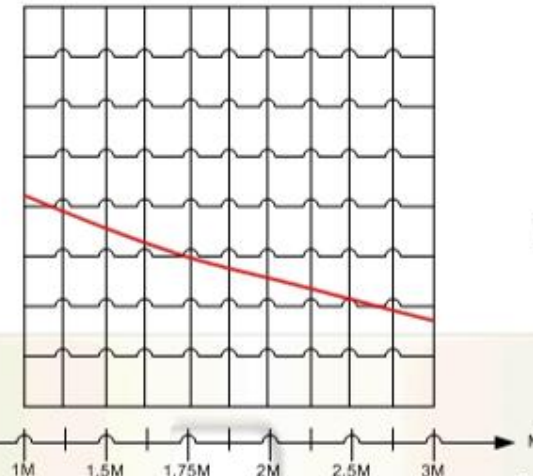

Thickness

2 mm



0.4

Safety Factor = 1.7

SUPPORT SPAN

Strengthened
CABLE LADDER



LOAD CAPACITY

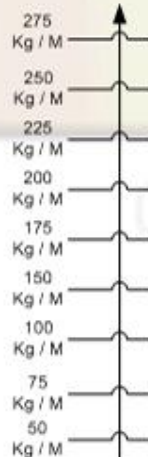

The Load Spaced Equal

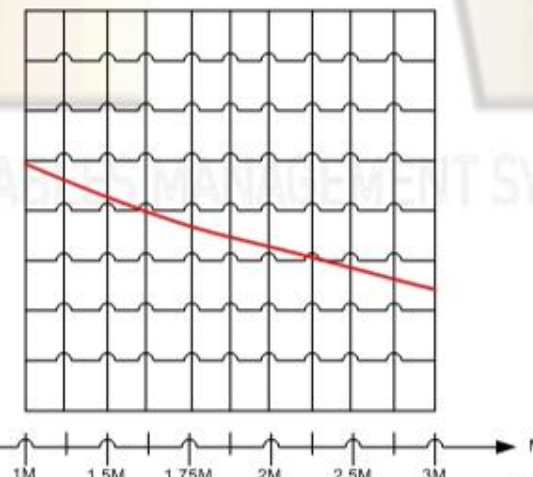

Thickness

2 mm



0.4

Safety Factor = 1.7

SUPPORT SPAN

SUPPORT SYSTEM

FEATURES :

- A choice of materials
- Designed to support cable trays, trunkings and cable ladders.
- Has great flexibility.

PARTICULARS:

- a complete All-purpose use of perforated sections.

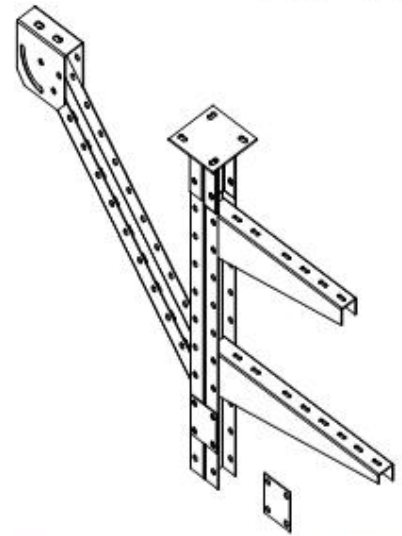

SIMPLE HANGING SYSTEM
(thickness 2.5 mm)

* Evaluate the L_u load per bracket

$$L_u = \text{cable weight per meter} \times \text{distance between supports} \quad (\text{N}) \quad (\text{N/m})$$

* Evaluate the Momentum

$$M = \sum_{w=1}^n w_u \times P_u \quad (\text{N.m}) \quad (\text{m}) \quad (\text{N})$$

$w_u = 1/2$ width of cable trays + overlength

* See loading graphs for deflection f according to length L of the hanging system. In practice the limit will be 1.5% of length L to take into account the possible over loads.

LOADING GRAPH

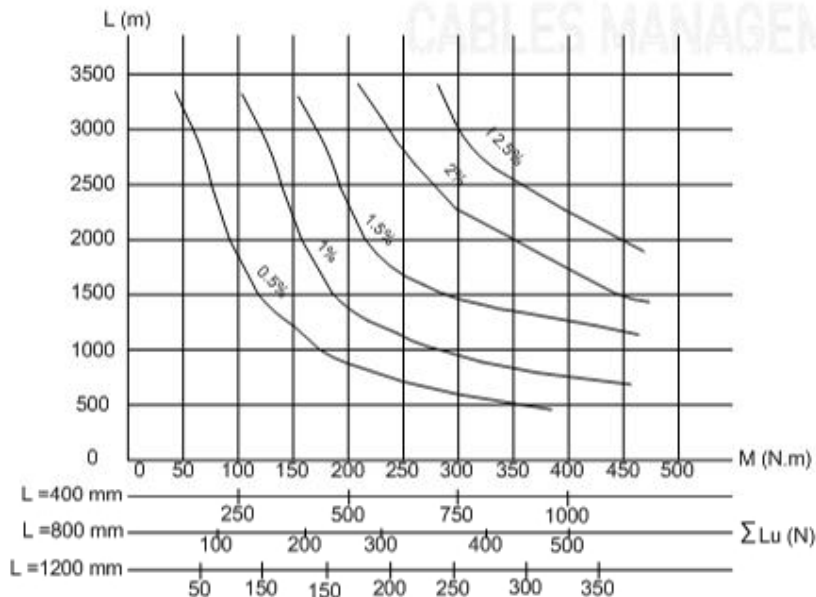
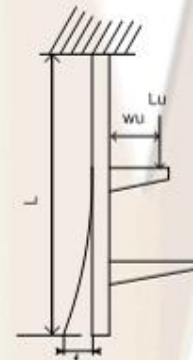
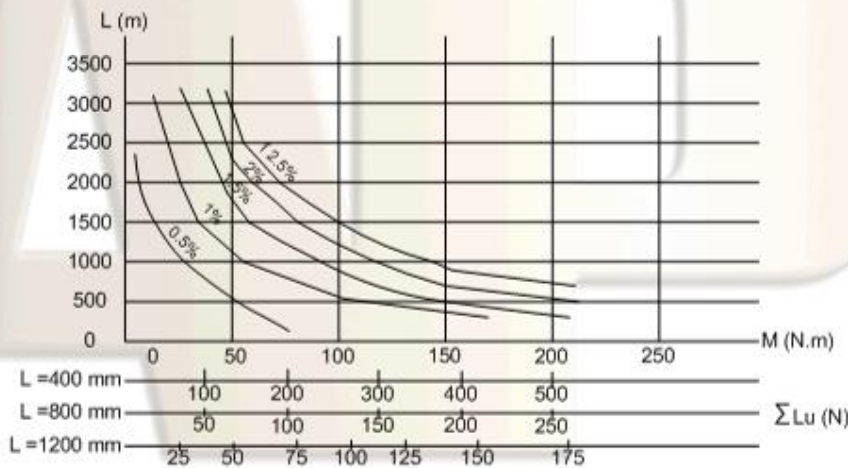

DOUBLE HANGING SYSTEM
(thickness 2.5 mm)

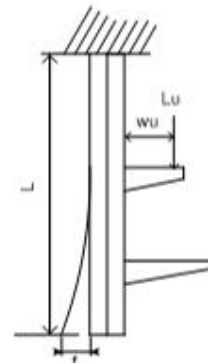

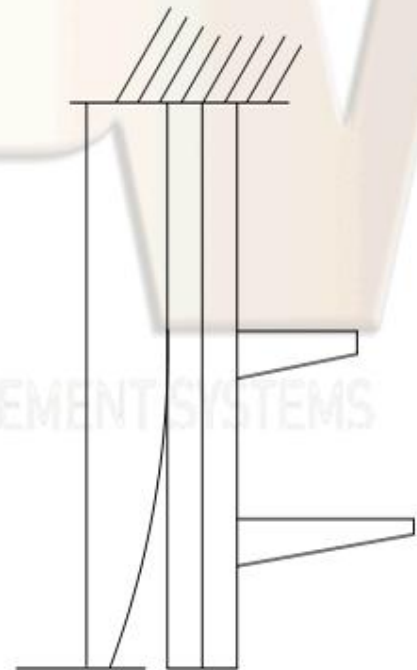
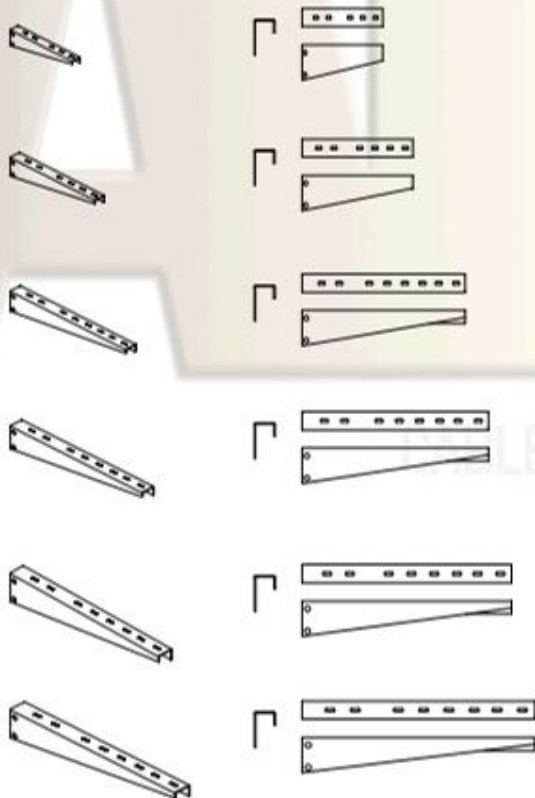
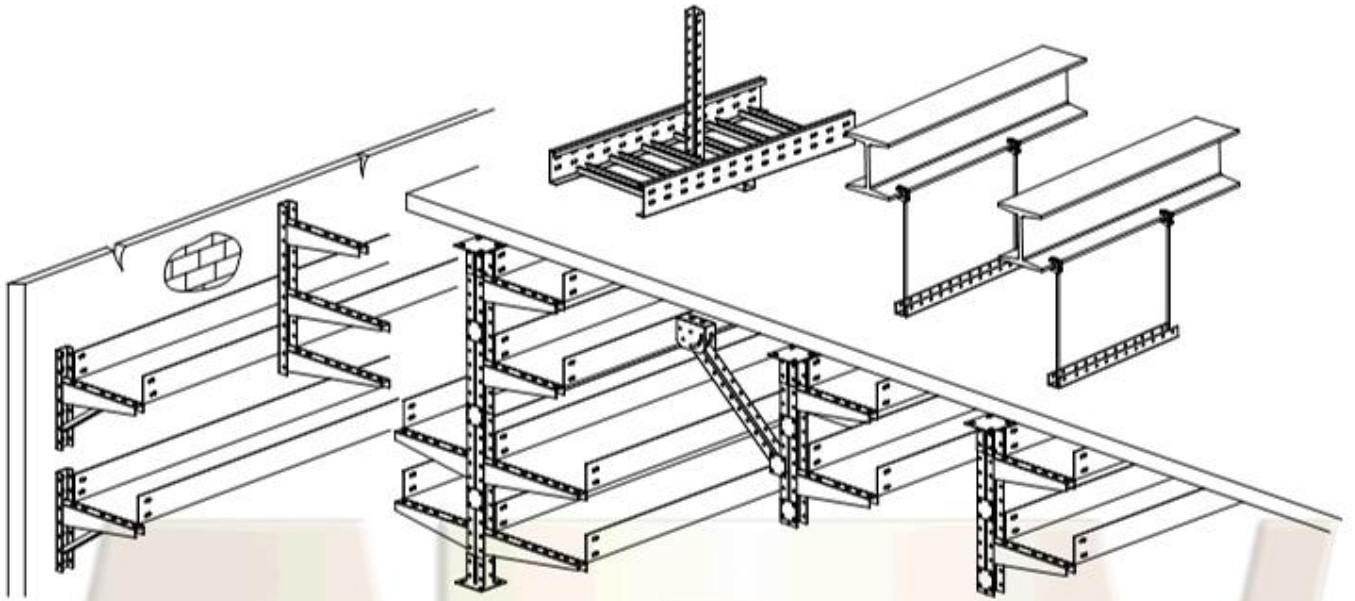



ISO 9001:2000
Reg. 7877-1

Annex F – Component dimensions

90 degree Flat Bend كوع مسطح 90 درجة

H 035

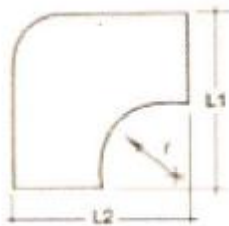

Dimensions					Thickness	CODE
H	W	L1	L2			
035	035	158	158	0.70	FB90 035 035	
035	040	180	180	0.70	FB90 035 040	
035	050	225	225	0.70	FB90 035 050	
050	050	225	225	1.00	FB90 050 050	
050	075	240	240	1.00	FB90 050 075	
050	100	265	265	1.00	FB90 050 100	
050	150	315	315	1.00	FB90 050 150	
050	200	365	365	1.00	FB90 050 200	
050	300	465	465	1.25	FB90 050 300	
050	400	565	565	1.25	FB90 050 400	
050	500	665	665	1.25	FB90 050 500	
050	600	765	765	1.25	FB90 050 600	
050	700	865	865	1.25	FB90 050 700	
050	800	965	965	1.25	FB90 050 800	
050	900	1065	1065	1.25	FB90 050 900	
075	075	240	240	1.00	FB90 075 075	
075	100	265	265	1.00	FB90 075 100	
075	150	315	315	1.00	FB90 075 150	
075	200	365	365	1.00	FB90 075 200	
075	300	465	465	1.25	FB90 075 300	
075	400	565	565	1.25	FB90 075 400	
075	500	665	665	1.25	FB90 075 500	
075	600	765	765	1.25	FB90 075 600	
075	700	865	865	1.25	FB90 075 700	
075	800	965	965	1.25	FB90 075 800	
075	900	1065	1065	1.25	FB90 075 900	
100	100	265	265	1.00	FB90 100 100	
100	150	315	315	1.00	FB90 100 150	
100	200	365	365	1.00	FB90 100 200	
100	300	465	465	1.25	FB90 100 300	
100	400	565	565	1.25	FB90 100 400	
100	500	665	665	1.25	FB90 100 500	
100	600	765	765	1.25	FB90 100 600	
100	700	865	865	1.25	FB90 100 700	
100	800	965	965	1.25	FB90 100 800	
100	900	1065	1065	1.25	FB90 100 900	

H 050

H 075

H 100

- All of the measurements above are in millimeters.
- Each item of the above is 125 Radius.
- All of the items above can be supplied with a complete earthing connectors set.
- All of the items above can be in one of the following finishes: Hot dipped galvanized, power painted, sendzimir galvanized, chrome or stainless steel.



ISO 9001:2000
Reg. 7977-1

CONSULTANTS EUROPE bv

TECHNICAL & LEGAL EXPERTS

45 degree Flat Bend نوع مسطح 45 درجة

H 035

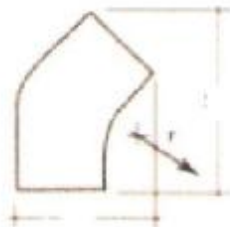

Dimensions					Thickness	CODE
H	W	L1	L2			
035	035	81	81	0.70	FB45 035 035	
035	040	92	92	0.70	FB45 035 040	
035	050	115	115	0.70	FB45 035 050	
050	050	115	115	1.00	FB45 050 050	
050	075	210	210	1.00	FB45 050 075	
050	100	226	226	1.00	FB45 050 100	
050	150	260	260	1.00	FB45 050 150	
050	200	297	297	1.00	FB45 050 200	
050	300	368	368	1.25	FB45 050 300	
050	400	439	439	1.25	FB45 050 400	
050	500	510	510	1.25	FB45 050 500	
050	600	581	581	1.25	FB45 050 600	
050	700	652	652	1.25	FB45 050 700	
050	800	723	723	1.25	FB45 050 800	
050	900	792	792	1.25	FB45 050 900	
075	075	210	210	1.00	FB45 075 075	
075	100	226	226	1.00	FB45 075 100	
075	150	260	260	1.00	FB45 075 150	
075	200	297	297	1.00	FB45 075 200	
075	300	268	268	1.25	FB45 075 300	
075	400	439	439	1.25	FB45 075 400	
075	500	510	510	1.25	FB45 075 500	
075	600	581	581	1.25	FB45 075 600	
075	700	652	652	1.25	FB45 075 700	
075	800	723	723	1.25	FB45 075 800	
075	900	792	792	1.25	FB45 075 900	
100	100	226	226	1.00	FB45 100 100	
100	150	260	260	1.00	FB45 100 150	
100	200	297	297	1.00	FB45 100 200	
100	300	268	268	1.25	FB45 100 300	
100	400	439	439	1.25	FB45 100 400	
100	500	510	510	1.25	FB45 100 500	
100	600	581	581	1.25	FB45 100 600	
100	700	652	652	1.25	FB45 100 700	
100	800	723	723	1.25	FB45 100 800	
100	900	792	792	1.25	FB45 100 900	

H 050

H 075

H 100

All of the measurements above are in millimeters.

Each item of the above is 125 Radius.

All of the items above can be supplied with a complete earthing connectors set.

All of the items above can be in one of the following finishes: Hot dipped galvanized, power painted, sendzimir galvanized, chrome or stainless steel.



ISO 9001:2000
Reg. 7977-1

CONSULTANTS EUROPE bv

TECHNICAL & LEGAL EXPERTS

90 degree Inside Riser

كروخ صعود 90 درجة

H 035

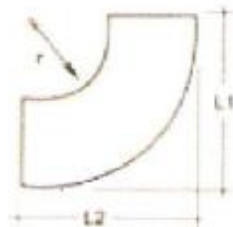

Dimensions					Thickness	CODE
H	W	L1	L2			
035	035	151	151	0.70	IR90 035 035	
035	040	151	151	0.70	IR90 035 040	
035	050	151	151	0.70	IR90 035 050	
050	050	215	215	1.00	IR90 050 050	
050	075	215	215	1.00	IR90 050 075	
050	100	215	215	1.00	IR90 050 100	
050	150	215	215	1.00	IR90 050 150	
050	200	215	215	1.00	IR90 050 200	
050	300	215	215	1.25	IR90 050 300	
050	400	215	215	1.25	IR90 050 400	
050	500	215	215	1.25	IR90 050 500	
050	600	215	215	1.25	IR90 050 600	
050	700	215	215	1.25	IR90 050 700	
050	800	215	215	1.25	IR90 050 800	
050	900	215	215	1.25	IR90 050 900	
075	075	240	240	1.00	IR90 075 075	
075	100	240	240	1.00	IR90 075 100	
075	150	240	240	1.00	IR90 075 150	
075	200	240	240	1.00	IR90 075 200	
075	300	240	240	1.25	IR90 075 300	
075	400	240	240	1.25	IR90 075 400	
075	500	240	240	1.25	IR90 075 500	
075	600	240	240	1.25	IR90 075 600	
075	700	240	240	1.25	IR90 075 700	
075	800	240	240	1.25	IR90 075 800	
075	900	240	240	1.25	IR90 075 900	
100	100	265	265	1.00	IR90 100 100	
100	150	265	265	1.00	IR90 100 150	
100	200	265	265	1.00	IR90 100 200	
100	300	265	265	1.25	IR90 100 300	
100	400	265	265	1.25	IR90 100 400	
100	500	265	265	1.25	IR90 100 500	
100	600	265	265	1.25	IR90 100 600	
100	700	265	265	1.25	IR90 100 700	
100	800	265	265	1.25	IR90 100 800	
100	900	265	265	1.25	IR90 100 900	

H 050

H 075

H 100

- All of the measurements above are in millimeters.
- Each item of the above is 125 Radius.
- All of the items above can be supplied with a complete earthing connectors set.
- All of the items above can be in one of the following finishes: Hot dipped galvanized, power painted, sendzimir galvanized, chrome or stainless steel.



ISO 9001:2000
Reg. 7977-1

CONSULTANTS EUROPE bv

TECHNICAL & LEGAL EXPERTS

45 degree Inside Riser

كوع صعود 45 درجة

H 035

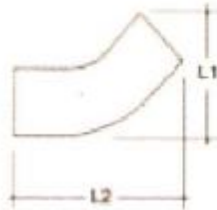

Dimensions					CODE
H	W	L1	L2	Thickness	
035	035	79	131	0.70	IR45 035 035
035	040	79	131	0.70	IR45 035 040
035	050	79	131	0.70	IR45 035 050
050	050	112	187	1.00	IR45 050 050
050	075	112	187	1.00	IR45 050 075
050	100	112	187	1.00	IR45 050 100
050	150	112	187	1.00	IR45 050 150
050	200	112	187	1.00	IR45 050 200
050	300	112	187	1.25	IR45 050 300
050	400	112	187	1.25	IR45 050 400
050	500	112	187	1.25	IR45 050 500
050	600	112	187	1.25	IR45 050 600
050	700	112	187	1.25	IR45 050 700
050	800	112	187	1.25	IR45 050 800
050	900	112	187	1.25	IR45 050 900
075	075	140	207	1.00	IR45 075 075
075	100	140	207	1.00	IR45 075 100
075	150	140	207	1.00	IR45 075 150
075	200	140	207	1.00	IR45 075 200
075	300	140	207	1.25	IR45 075 300
075	400	140	207	1.25	IR45 075 400
075	500	140	207	1.25	IR45 075 500
075	600	140	207	1.25	IR45 075 600
075	700	140	207	1.25	IR45 075 700
075	800	140	207	1.25	IR45 075 800
075	900	140	207	1.25	IR45 075 900
100	100	165	227	1.00	IR45 100 100
100	150	165	227	1.00	IR45 100 150
100	200	165	227	1.00	IR45 100 200
100	300	165	227	1.25	IR45 100 300
100	400	165	227	1.25	IR45 100 400
100	500	165	227	1.25	IR45 100 500
100	600	165	227	1.25	IR45 100 600
100	700	165	227	1.25	IR45 100 700
100	800	165	227	1.25	IR45 100 800
100	900	165	227	1.25	IR45 100 900

H 050

H 075

H 100

- All of the measurements above are in millimeters.
- Each item of the above is 125 Raduis.
- All of the items above can be supplied with a complete earthing connectors set.
- All of the items above can be in one of the following finishes: Hot dipped galvanized, power painted, sendzimir galvanized, chrome or stainless steel.



ISO 9001:2000
Reg. 7977-1

CONSULTANTS EUROPE bv

TECHNICAL & LEGAL EXPERTS

90 degree Outside Riser

كروم نزول 90 درجة

H 035

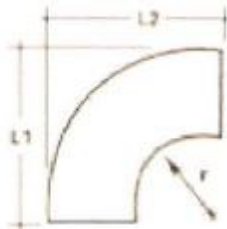
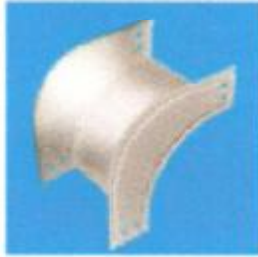

Dimensions					CODE
H	W	L1	L2	Thickness	
035	035	151	151	0.70	OR90 035 035
035	040	151	151	0.70	OR90 035 040
035	050	151	151	0.70	OR90 035 050
050	050	215	215	1.00	OR90 050 050
050	075	215	215	1.00	OR90 050 075
050	100	215	215	1.00	OR90 050 100
050	150	215	215	1.00	OR90 050 150
050	200	215	215	1.00	OR90 050 200
050	300	215	215	1.25	OR90 050 300
050	400	215	215	1.25	OR90 050 400
050	500	215	215	1.25	OR90 050 500
050	600	215	215	1.25	OR90 050 600
050	700	215	215	1.25	OR90 050 700
050	800	215	215	1.25	OR90 050 800
050	900	215	215	1.25	OR90 050 900
075	075	240	240	1.00	OR90 075 075
075	100	240	240	1.00	OR90 075 100
075	150	240	240	1.00	OR90 075 150
075	200	240	240	1.00	OR90 075 200
075	300	240	240	1.25	OR90 075 300
075	400	240	240	1.25	OR90 075 400
075	500	240	240	1.25	OR90 075 500
075	600	240	240	1.25	OR90 075 600
075	700	240	240	1.25	OR90 075 700
075	800	240	240	1.25	OR90 075 800
075	900	240	240	1.25	OR90 075 900
100	100	265	265	1.00	OR90 100 100
100	150	265	265	1.00	OR90 100 150
100	200	265	265	1.00	OR90 100 200
100	300	265	265	1.25	OR90 100 300
100	400	265	265	1.25	OR90 100 400
100	500	265	265	1.25	OR90 100 500
100	600	265	265	1.25	OR90 100 600
100	700	265	265	1.25	OR90 100 700
100	800	265	265	1.25	OR90 100 800
100	900	265	265	1.25	OR90 100 900

H 050

H 075

H 100

- All of the measurements above are in millimeters.
- Each item of the above is 125 Radius.
- All of the items above can be supplied with a complete earthing connectors set.
- All of the items above can be in one of the following finishes: Hot dipped galvanized, power painted, sendzimir galvanized, chrome or stainless steel.



ISO 9001:2000
Reg. 7977-1

45 degree Outside Riser كروخ نزول 45 درجة

H 035

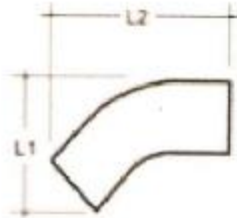

Dimensions					CODE
H	W	L1	L2	Thickness	
035	035	79	131	0.70	OR45 035 035
035	040	79	131	0.70	OR45 035 040
035	050	79	131	0.70	OR45 035 050
050	050	112	187	1.00	OR45 050 050
050	075	112	187	1.00	OR45 050 075
050	100	112	187	1.00	OR45 050 100
050	150	112	187	1.00	OR45 050 150
050	200	112	187	1.00	OR45 050 200
050	300	112	187	1.25	OR45 050 300
050	400	112	187	1.25	OR45 050 400
050	500	112	187	1.25	OR45 050 500
050	600	112	187	1.25	OR45 050 600
050	700	112	187	1.25	OR45 050 700
050	800	112	187	1.25	OR45 050 800
050	900	112	187	1.25	OR45 050 900
075	075	140	207	1.00	OR45 075 075
075	100	140	207	1.00	OR45 075 100
075	150	140	207	1.00	OR45 075 150
075	200	140	207	1.00	OR45 075 200
075	300	140	207	1.25	OR45 075 300
075	400	140	207	1.25	OR45 075 400
075	500	140	207	1.25	OR45 075 500
075	600	140	207	1.25	OR45 075 600
075	700	140	207	1.25	OR45 075 700
075	800	140	207	1.25	OR45 075 800
075	900	140	207	1.25	OR45 075 900
100	100	165	227	1.00	OR45 100 100
100	150	165	227	1.00	OR45 100 150
100	200	165	227	1.00	OR45 100 200
100	300	165	227	1.25	OR45 100 300
100	400	165	227	1.25	OR45 100 400
100	500	165	227	1.25	OR45 100 500
100	600	165	227	1.25	OR45 100 600
100	700	165	227	1.25	OR45 100 700
100	800	165	227	1.25	OR45 100 800
100	900	165	227	1.25	OR45 100 900

H 050

H 075

H 100

All of the measurements above are in millimeters.

Each item of the above is 125 Radius.

All of the items above can be supplied with a complete earthing connectors set.

All of the items above can be in one of the following finishes: Hot dipped galvanized, power painted, sendzimir galvanized, chrome or stainless steel.

NEMIA VE 1

**METAL CABLE TRAY
SYSTEMS**

NEMA Standards Publication VE 1-2009

Canadian Standards Association Publication CSA C22.2 No. 126.1-09

Metal Cable Tray Systems

Published by:

National Electrical Manufacturers Association
1300 North 17th Street
Rosslyn, Virginia 22209

www.nema.org

In Canada, published by:

Canadian Standards Association
5060 Spectrum Way, Suite 100
Mississauga, ON, Canada L4W 5N6

www.csa.ca

© Copyright 2009 by the National Electrical Manufacturers Association. All rights including translation into other languages, reserved under the Universal Copyright Convention, the Berne Convention for the Protection of Literary and Artistic Works, and the International and Pan American Copyright Conventions.

© Copyright 2009 ISBN 1-55324-497-4

Canadian Standards Association

All rights reserved. No part of this publication may be reproduced in any form whatsoever without the prior permission of the publisher.

Commitment for Amendments

This Standard is issued jointly by Canadian Standards Association (CSA) and the National Electrical Manufacturers Association (NEMA). Amendments to this Standard will be made only after processing according to the standards-writing procedures of CSA and NEMA.

NOTICE AND DISCLAIMER

The information in this publication was considered technically sound by the consensus of persons engaged in the development and approval of the document at the time it was developed. Consensus does not necessarily mean that there is unanimous agreement among every person participating in the development of this document.

The National Electrical Manufacturers Association (NEMA) standards and guideline publications, of which the document contained herein is one, are developed through a voluntary consensus standards development process. This process brings together volunteers and/or seeks out the views of persons who have an interest in the topic covered by this publication. While NEMA administers the process and establishes rules to promote fairness in the development of consensus, it does not write the document and it does not independently test, evaluate, or verify the accuracy or completeness of any information or the soundness of any judgments contained in its standards and guideline publications.

NEMA disclaims liability for any personal injury, property, or other damages of any nature whatsoever, whether special, indirect, consequential, or compensatory, directly or indirectly resulting from the publication, use of, application, or reliance on this document. NEMA disclaims and makes no guaranty or warranty, expressed or implied, as to the accuracy or completeness of any information published herein, and disclaims and makes no warranty that the information in this document will fulfill any of your particular purposes or needs. NEMA does not undertake to guarantee the performance of any individual manufacturer or seller's products or services by virtue of this standard or guide.

In publishing and making this document available, NEMA is not undertaking to render professional or other services for or on behalf of any person or entity, nor is NEMA undertaking to perform any duty owed by any person or entity to someone else. Anyone using this document should rely on his or her own independent judgment or, as appropriate, seek the advice of a competent professional in determining the exercise of reasonable care in any given circumstances. Information and other standards on the topic covered by this publication may be available from other sources, which the user may wish to consult for additional views or information not covered by this publication.

NEMA has no power, nor does it undertake to police or enforce compliance with the contents of this document. NEMA does not certify, test, or inspect products, designs, or installations for safety or health purposes. Any certification or other statement of compliance with any health or safety-related information in this document shall not be attributable to NEMA and is solely the responsibility of the certifier or maker of the statement.

CONTENTS

Preface	iii
Foreword (NEMA)	iv
Section 1 SCOPE.....	1
Section 2 DEFINITIONS AND ABBREVIATIONS.....	2
2.1 Definitions.....	2
2.2 Abbreviations.....	3
Section 3 GENERAL	4
3.1 Reference Publications	4
3.2 Units of Measurement	4
Section 4 CONSTRUCTION	5
4.1 Materials.....	5
4.2 Finishes.....	5
4.3 Typical Dimensions	6
4.3.1 General.....	6
4.3.2 Lengths of Straight Sections.....	6
4.3.3 Widths.....	6
4.3.4 Fill Depths.....	7
4.3.5 Nominal Rung Spacings on Straight Sections.....	7
4.3.6 Inside Radii.....	7
4.3.7 Degrees of Arc for Elbows.....	7
4.4 Quality of Work.....	8
4.5 Fittings.....	8
4.6 Fasteners	8
4.7 Bonding	8
4.8 Load Capacity	8
Section 5 TESTS.....	9
5.1 Electrical Continuity of Connections.....	9
5.2 Load Testing.....	9
5.2.1 General.....	9
5.2.2 Test Specimen.....	9
5.2.3 Type and Length of Span	9
5.2.4 Orientation of Specimen	9
5.2.5 Supports	9
5.2.6 Loading Material	10
5.2.7 Load Application.....	10
5.2.8 Loading to Destruction (Method A).....	10
5.2.9 Loading to Residual Deflection (Method B).....	11
5.3 Interpolation of Test Data—For Use with 5.2.8 (Method A) Only	11
5.4 Rung Load Capacity (Optional).....	11
5.4.1 General.....	11
5.4.2 Test Equipment	12
5.4.3 Test Specimen.....	12
5.4.4 Span Length and Supports.....	12
5.4.5 Orientation of Specimens	12
5.4.6 Loading.....	12

5.4.7	Load Capacity.....	12
5.4.8	Interpolation of Rung Load Test Data.....	12
Section 6 PRODUCT MARKING, INFORMATION, AND INSTALLATION		13
6.1	Marking on Product	13
6.2	Product Information	13
6.3	Cable Tray Installation.....	13

Tables

Table 1	Span/Load Class Designation—USA.....	14
Table 2	Span/Load Class Designation—CANADA	14

Figures

Figure 1	Illustration of Selected Definitions	15
Figure 2	Application of Load—Rung Load Capacity	16

Annex (informative)

Annex A	Markings—French Translations	17
---------	------------------------------------	----

Preface

This is the common CSA and NEMA Standard for Metal Cable Tray Systems. It is the third edition of C22.2 No. 126.1, superseding the previous editions published in 2002 and 1998, and the fifth edition of NEMA VE 1, superseding the previous edition published in 2002.

This common Standard was prepared by the CANENA Technical Harmonization Committee for Metal Cable Tray Systems, comprising members from the Canadian Standards Association, National Electrical Manufacturers Association, and the cable tray manufacturing industry. The efforts of the CANENA Technical Harmonization Committee are gratefully acknowledged.

This standard is considered suitable for use for conformity assessment within the stated scope of the standard.

This Standard was reviewed by the CSA Subcommittee on Cable Tray Systems under the jurisdiction of the Technical Committee on Wiring Products and the Strategic Resource Group, and has been formally approved by the Technical Committee. Where reference is made to a specific number of samples to be tested, the specified number is considered to be a minimum quantity. This Standard was also approved at NEMA by the Codes and Standards Committee.

NOTE—Although the intended primary application of this Standard is stated in its Scope, it is important to note that it remains the responsibility of the users of the Standard to judge its suitability for their particular purpose.

Level of Harmonization

This Standard uses an IEC format, but is not based on, nor is it to be considered equivalent to, an IEC standard. This Standard is published as an equivalent standard.

An equivalent standard is a standard that is substantially the same in technical content, except as follows. Technical deviations are allowed for Codes and Governmental Regulations and those recognized as being in accordance with NAFTA Article 905, for example, because of fundamental, climatic, geographical, technological, or infrastructural factors, scientific justification, or the level of protection that the country considers appropriate. Presentation of the NEMA and CSA versions is to be word for word except for editorial changes.

Reasons for Differences to IEC

The Technical Harmonization Committee (THC) identified one IEC standard that addresses electrical cable tray systems included in the scope of this Standard. The THC determined the safe use of electrical cable tray is dependent on the design, performance, and installation of the cable tray system. The IEC standard does not mention the equipment grounding function of cable tray, and there are no requirements for corrosion protection at this time. Significant investigation is required to assess safety and system issues that may lead to harmonization of traditional North American electrical cable tray standards with those presently addressed in the known IEC standard. The THC agreed such future investigation might be facilitated by completion of harmonization of the North American standards for electrical cable tray.

Interpretations

The interpretation by the Standards Development Organization (SDO) of an identical or equivalent standard is to be based on the literal text to determine compliance with the standard in accordance with the procedural rules of the SDO. If more than one interpretation of the literal text has been identified, a revision is to be proposed as soon as possible to each of the SDOs to more accurately reflect the intent.

CSA Effective Date

The effective date for CSA will be announced through *CSA Informs* or a CSA Certification Notice.

NEMA Effective Date

The effective date for NEMA will be the publication date.

Foreword (NEMA)

This Standards Publication provides technical requirements concerning the construction, testing, and performance of metal cable tray systems. The development of this publication is the result of many years of research, investigation, and experience by the members of the Cable Tray Section of NEMA. Throughout the development of this publication, test methods and performance values have been related as closely as possible to end-use applications. It has been developed through consultation among manufacturers, with users and engineering societies, to result in improved serviceability and safety of metal cable tray systems.

This publication reflects the study of applicable building codes and the *National Electrical Code*[®], and adheres to applicable national material and manufacturing standards, such as those of the American Society for Testing and Materials, the American Iron and Steel Institute, the Aluminum Association, and Underwriters Laboratories, Inc. The NEMA Cable Tray Section periodically reviews this publication for any revisions necessary, to keep it up to date with advancing technology.

Comments or recommended revisions are welcomed and should be submitted to:

Vice President, Technical Services
National Electrical Manufacturers Association
1300 North 17th Street, Suite 1752
Rosslyn, Virginia 22209

The primary purpose of this Standards Publication is to encourage the manufacture and utilization of standardized metal cable tray systems and to eliminate misunderstandings between manufacturers and users.

The cable tray system manufacturer has limited or no control over the following factors, which are vital to a safe installation:

- a. environmental conditions;
- b. system design;
- c. product selection and application;
- d. installation practices; and
- e. system maintenance.

This Standards Publication was developed by the Cable Tray Section, and has been promulgated with a view toward promoting safety of persons and property by the proper selection and use of metal cable tray systems. At the time it was approved, the Cable Tray Section was composed of the following members:

Cablofil, Inc.—Mascoutah, IL
Chalfant Manufacturing Company—Cleveland, OH
Cooper B-Line—Highland, IL
Cope/Allied Electrical Group—Harvey, IL
MP Husky Corporation—Greenville, SC
P-W Industries, Inc.—Atlanta, GA
The Wiremold Company—West Hartford, CT
Thomas & Betts Corporation—Memphis, TN

Section 1

SCOPE

This Standard specifies the requirements for metal cable trays and associated fittings designed for use in accordance with the rules of the *Canadian Electrical Code (CEC), Part I*, and the *National Electrical Code (NEC)*.

Section 2 DEFINITIONS AND ABBREVIATIONS

2.1 DEFINITIONS

The following definitions apply in this Standard (see also Figure 1):

accessory: Components used to supplement the function of a straight section or fitting. Examples include, but are not limited to, dropout, cover, conduit adapter, hold-down device, and divider.

cable tray support span: The distance between the centerlines of supports.

cable tray system: A section or assembly of sections, and associated fittings, forming a mechanical system used to support cables and raceways.

channel cable tray: A fabricated structure consisting of a one-piece ventilated-bottom or solid-bottom channel section.

connector: A component that joins any combination of cable tray straight sections and fittings. The basic types of connectors include rigid, expansion, adjustable, and reducer.

fasteners: Screws, nuts, bolts, washers, rivets, spacers, pins, and other items used to connect and assemble cable tray systems.

fill depth: The vertical interior dimension of a cable tray that is used to calculate the allowable interior cross-sectional area.

fitting: A component that is used to change the size or direction of a cable tray system.

horizontal cross: A fitting that joins cable trays in four directions at 90° intervals in the same plane.

horizontal elbow: A fitting that changes the direction of cable tray in the same plane.

horizontal tee: A fitting that joins cable trays in three directions at 90° intervals in the same plane.

horizontal wye: A fitting that joins cable trays in three directions at other than 90° intervals in the same plane.

ladder cable tray: A fabricated structure consisting of two longitudinal side rails connected by individual transverse members (rungs).

reducer: A fitting that joins cable trays of different widths in the same plane.

left-hand reducer: A reducer having, when viewed from the large end, a straight side on the left.

right-hand reducer: A reducer having, when viewed from the large end, a straight side on the right.

straight reducer: A reducer having two symmetrical offset sides.

single-rail cable tray: A fabricated structure consisting of a longitudinal rail with transversely connected members (rungs) that project from one side (side-supported) or both sides (center-supported), which may be single- or multi-tier.

solid-bottom or nonventilated cable tray: A fabricated structure consisting of a bottom without ventilation openings within integral or separate longitudinal side rails.

straight section: A length of cable tray that has no change in direction or size.

support: A component that provides a means for supporting a cable tray, including, but not limited to, cantilever bracket, trapeze, and individual rod suspension.

trough or ventilated cable tray: A fabricated structure consisting of integral or separate longitudinal rails and a bottom having openings sufficient for the passage of air and utilizing 75% or less of the plan area of the surface to support cables where the maximum open spacings between cable support surfaces of transverse elements do not exceed 100 mm (4 in.) in the direction parallel to the tray side rails.

NOTES—

- (1) On horizontal bends only, the maximum distance between transverse elements is measured at the centerline of the bend.
- (2) A ladder cable tray having rung spacing such that the cable tray meets the definition described above is considered to be a ventilated cable tray.

vertical elbow: A fitting that changes the direction of cable tray to a different plane.

inside vertical elbow: A fitting that changes the direction of cable tray upward from the horizontal plane.

outside vertical elbow: A fitting that changes the direction of cable tray downward from the horizontal plane.

vertical tee: A fitting that joins cable trays in three directions at 90° intervals in different planes.

wire mesh cable tray: A manufactured wire mesh tray consisting of steel wires welded at all intersections. Longitudinal wires located on the exterior of the tray are spaced at a maximum of 50 mm (2 in.) and transverse wires are spaced at a maximum of 100 mm (4 in.).

wire mesh cable tray fitting: A fitting for wire mesh cable tray systems, fabricated from wire mesh cable tray straight sections. The fitting is field-constructed and attached to the adjacent sections using splice connectors in accordance with the manufacturer's instructions.

2.2 ABBREVIATIONS

The following abbreviations apply in this standard:

- A — ampere
- ac — alternating current
- °C — degrees Celsius
- dc — direct current
- °F — degrees Fahrenheit
- ft — foot
- in. — inch
- kg — kilogram
- lb — pound
- lin ft — linear foot
- lin m — linear meter
- m — meter
- min — minute
- mm — millimeter
- Ω — ohm
- SI — International System of Units (metric)

Section 3 GENERAL

3.1 REFERENCE PUBLICATIONS

Where reference is made to other publications, such reference shall be considered to refer to the latest edition and all amendments published to that edition up to the time when this Standard was approved.

Canadian Standards Association (CSA)
5060 Spectrum Way, Suite 100
Mississauga, ON, Canada L4W 5N6

C22.1-09 *Canadian Electrical Code, Part I*

National Electrical Manufacturers Association (NEMA)
1300 North 17th Street, Suite 1752
Rosslyn, Virginia 22209

VE 2-2006 *Cable Tray Installation Guidelines*

American National Standards Institute (ANSI)
11 West 42nd Street
New York, NY 10036

ANSI/NFPA 70-2008 *National Electrical Code*

American Society for Testing and Materials (ASTM)
1916 Race Street
Philadelphia, PA 19103

A 123/A 123M-02 *Standard Specification for Zinc (Hot-Dip Galvanized) Coatings on Iron and Steel Products*

A 653/A 653M-06 *Standard Specification for Steel Sheet, Zinc-Coated (Galvanized) or Zinc-Iron Alloy-Coated (Galvannealed) by the Hot-Dip Process*

B 633-07 *Standard Specification for Electrodeposited Coatings of Zinc on Iron and Steel*

3.2 UNITS OF MEASUREMENT

The values given in SI (metric) units are mandatory. Any other values given are for information only.

NOTE—Lengths are shown in millimeters or meters (inches or feet). Widths, deflections, and similar measurements are generally defined in millimeters (fractions of inches), and load-bearing capacity in kilograms/meter (pounds/foot).

Section 4 CONSTRUCTION

4.1 MATERIALS

Cable tray systems shall be made of either corrosion-resistant metal, such as aluminum or stainless steel, or metal with a corrosion-resistant finish.

4.2 FINISHES

4.2.1 Carbon steel used for cable trays shall be protected against corrosion by one of the following processes:

(a) Type 1—Hot-dip galvanizing after fabrication in accordance with ASTM A 123/A 123M;

NOTE—Fabricated products that are hot-dip galvanized are thoroughly cleaned, fluxed, and immersed in a bath of molten zinc, where they react to form a metallurgically bonded zinc coating. Normal oxidation of the galvanized surfaces will, in a short period of time, appear as a dull gray or white coating. Some degree of roughness and variations of thicknesses can be expected as a result of the hot-dipping process. Because the galvanizing process takes place at the low end of the stress-relieving temperature range, some stress relief occurs, and some distortion or warping may result.

(b) Type 2—Hot-dip mill galvanizing in accordance with ASTM A 653/A 653M, coating designation G90;

NOTE—Hot-dip mill galvanized coatings are produced by continuously rolling steel sheets or strips in coils through a bath of molten zinc. The process involves pretreating the steel to make the surface react readily with molten zinc as the strip moves through the bath at high speeds. During fabrication, where slitting, forming, cutting, or welding is performed, the cut edges and heat-affected zone of welding are subject to superficial oxidation. These areas are then protected through electrolytic action of the adjacent zinc surfaces. The coating is smooth, ductile, and adherent.

NOTE—For corrosive or wet locations, other coatings may be more suitable.

(c) Type 3—Electrodeposited zinc in accordance with ASTM B 633 (SC 2 minimum); or

NOTE—Fabricated products that are to receive electrodeposited zinc (zinc plated) coatings are thoroughly cleaned and then a thin layer of zinc is deposited by electrolysis. A conversion coating can then be applied to the zinc surface, resulting in a colored (typically yellow) or colorless (clear-blue) appearance. Electrodeposited zinc is a common indoor finish for wire mesh cable trays. For corrosive or wet locations, other coatings or materials may be more suitable.

(d) Other coatings as appropriate for the application. Where a nationally recognized standard exists, the coating shall be applied in accordance with that standard.

4.2.2 For installations in highly corrosive environments, such as alkaline or acidic conditions, different or additional protective coatings may be provided, as agreed to between the end user and the manufacturer.

4.2.3 Carbon steel nuts and bolts shall be protected against corrosion by one of the following processes:

(a) Zinc electroplating in accordance with ASTM B 633; or

(b) other coatings as appropriate for the application. Where a nationally recognized standard exists, the coating shall be applied in accordance with that standard.

4.3 TYPICAL DIMENSIONS

4.3.1 General

Clauses 4.3.2 to 4.3.7 provide the typical dimensions used in the industry. Other dimensions shall also be acceptable. Dimensions are based on rationalized conversions.

4.3.2 Lengths of Straight Sections

Typical lengths, not including connectors, are:

- (a) 3 m \pm 5 mm (10 ft \pm 3/16 in.);
- (b) 3.66 m \pm 5 mm (12 ft \pm 3/16 in.);
- (c) 6 m \pm 9 mm (20 ft \pm 5/16 in.); and
- (d) 7.32 m \pm 9 mm (24 ft \pm 5/16 in.).

4.3.3 Widths

4.3.3.1 For sections other than channel cable trays or wire mesh cable trays, typical widths are:

- (a) 150 mm (6 in.);
- (b) 225 mm (9 in.);
- (c) 300 mm (12 in.);
- (d) 450 mm (18 in.);
- (e) 600 mm (24 in.);
- (f) 750 mm (30 in.); and
- (g) 900 mm (36 in.).

NOTE—The tolerance of the widths is within \pm 6 mm (1/4 in.) for inside dimensions.

Overall width shall not exceed the inside width by more than 100 mm (4 in.).

4.3.3.2 For channel cable trays, typical widths are:

- (a) 75 mm (3 in.);
- (b) 100 mm (4 in.); and
- (c) 150 mm (6 in.).

NOTE—The tolerance of the widths is within \pm 6 mm (1/4 in.) for inside dimensions.

4.3.3.3 For wire mesh cable trays, typical widths are:

- (a) 50 mm (2 in.);
- (b) 100 mm (4 in.);
- (c) 150 mm (6 in.);
- (d) 200 mm (8 in.);
- (e) 300 mm (12 in.);
- (f) 400 mm (16 in.);
- (g) 450 mm (18 in.);
- (h) 500 mm (20 in.); and
- (i) 600 mm (24 in.).

NOTE—The tolerance of the widths is within \pm 3 mm (1/8 in.) for inside dimensions.

4.3.4 Fill Depths

4.3.4.1 For other than channel cable trays or wire mesh cable trays, typical depths for sections are:

- (a) 75 mm (3 in.);
- (b) 100 mm (4 in.);
- (c) 125 mm (5 in.); and
- (d) 150 mm (6 in.).

NOTE—The tolerance of the depths is within ± 10 mm (3/8 in.).

Outside depths shall not exceed inside depths by more than 30 mm (1-1/4 in.).

4.3.4.2 For channel cable trays, typical depths are 30–50 mm (1-1/4–2 in.) for outside dimensions.

4.3.4.3 For wire mesh cable trays, typical depths are:

- (a) 25 mm (1 in.);
- (b) 50 mm (2 in.);
- (c) 100 mm (4 in.); and
- (d) 150 mm (6 in.).

NOTE—The tolerance of the depths is within ± 10 mm (3/8 in.).

Outside depths shall not exceed inside depths by more than 30 mm (1-1/4 in.).

4.3.4.4 For single-rail cable trays, typical depths are:

- (a) 75 mm (3 in.);
- (b) 100 mm (4 in.);
- (c) 125 mm (5 in.); and
- (d) 150 mm (6 in.).

NOTE—The tolerance of the depths is within ± 10 mm (3/8 in.).

4.3.5 Nominal Rung Spacings on Straight Sections

Typical rung spacings are:

- (a) 150 mm (6 in.);
- (b) 225 mm (9 in.); and
- (c) 300 mm (12 in.).

4.3.6 Inside Radii

Typical inside radii of curved sections are:

- (a) 300 mm (12 in.);
- (b) 600 mm (24 in.); and
- (c) 900 mm (36 in.).

4.3.7 Degrees of Arc for Elbows

Typical degrees of arc for elbow sections are:

- (a) 30°;
- (b) 45°;
- (c) 60°; and
- (d) 90°.

4.4 QUALITY OF WORK

Cable tray systems shall be free from burrs or other sharp projections that could cause damage to the cable jacket during installation.

4.5 FITTINGS

Fittings shall not be required to be subjected to the load test described in Clause 5.2.

NOTE—Since fittings are not load-tested, they will not meet the strength requirements of straight sections unless supported as shown in NEMA VE 2, or in accordance with the manufacturer's instructions.

4.6 FASTENERS

Fasteners used for connection and assembly of a cable tray system shall be supplied according to the manufacturer's instructions and shall comply with the requirements of Clause 4.2.3.

4.7 BONDING

4.7.1 Cable tray systems shall be provided with connection means meeting the requirements of Clause 5.1.

4.7.2 Where paint or additional coatings are applied to components of the cable tray system, means shall be provided to ensure a measured resistance in accordance with Clause 5.1.

4.8 LOAD CAPACITY

4.8.1 Straight sections of cable tray shall meet the requirements of the test specified in Clause 5.2. See also Clause 5.3.

NOTES—

(1) The load ratings in Table 1 and Table 2 are those most commonly used.

(2) See Clause 5.3 for interpolation of test data when determining the load rating of spans shorter than the tested span.

4.8.2 A concentrated static load is not included in Table 1 and Table 2. Some user applications may require that a given concentrated static load be imposed over and above the working load. Depending on concentrated load value and location of load, some cable tray systems may not be suitable for support. When considering a concentrated load applied other than described below, consult the manufacturer.

A concentrated static load represents a static weight applied on the centerline of the tray at midspan. When so specified, the concentrated static load may be converted to an equivalent uniform load (W_e) in kg/lin m (lb/lin ft), using the following formula, and added to the static weight of cables in the tray:

$$W_e = \frac{2 \times (\text{concentrated static load, kg (lb)})}{\text{span length, m (ft)}}$$

4.8.3 Channel cable tray straight sections not exceeding 150 mm (6 in.) in width and 50 mm (2 in.) in depth need not be load-tested in accordance with Clause 5.2.

Section 5 TESTS

5.1 ELECTRICAL CONTINUITY OF CONNECTIONS

5.1.1 Each specimen shall consist of two 600 mm (24 in.) minimum lengths of standard spliced or coupled sections.

5.1.2 A current of 30 A dc shall be passed through the specimen and the resistance measured between two points located 1.6 mm (1/16 in.) from each side of the splice or coupling. The net resistance of the connection shall be not more than 0.00033 Ω as computed from the measured voltage drop and current passing through the specimen, at an ambient temperature of 15–35°C (60–95°F). The current source shall be applied at least 300 mm (12 in.) on either side of the splice or coupling.

5.2 LOAD TESTING

5.2.1 General

Cable tray specimens shall be subjected to either loading to destruction (Method A), as specified in Clause 5.2.8, or loading to residual deflection (Method B), as specified in Clause 5.2.9. For wire mesh trays, only Method A shall be used.

5.2.2 Test Specimen

For each design of cable tray, two specimens shall be tested. An unspliced straight section of the greatest width shall be used in each test.

For trays with rungs, rung spacings shall be the largest in a particular class.

Differences in gauge, wire diameter, height of rail(s), rung design, rung spacing greater than the tested spacings, bottom to rail connection, or in the configuration of any part shall constitute a different design.

Coated trays need not be tested, provided that bare or pregalvanized trays of the same class have been tested.

5.2.3 Type and Length of Span

The test specimen shall be a simple beam span, with free unrestrained ends. Trays shall not have side restraints. Span lengths shall be as specified, with a tolerance of ± 38 mm (1-1/2 in.).

Side-mounted single-rail cable trays shall have restrained ends.

5.2.4 Orientation of Specimen

Specimens shall be tested in the horizontal position. The total length of the test specimen shall be not more than the specified span length + 20%. Any overhang shall be equally distributed beyond both supports.

5.2.5 Supports

Each end of the specimen shall be supported by a steel bar(s) of 30 mm (1-1/8 in.) width and 19 mm (3/4 in.) height, with a 120° V-notch cut in its bottom to a depth of 5 mm (3/16 in.). The V-notch shall rest on a 25 mm (1 in.) solid round steel bar fastened to a rigid base, or the specimen shall be supported directly on a 65 mm (2-1/2 in.) diameter round steel bar or heavy wall steel tube fastened to a rigid base.

At the supports, single-rail trays may have side restraints that do not constrain vertical movement.

Side-mounted single-rail cable tray specimens shall be supported to the wall as recommended by the manufacturer at both ends and at mid-point.

5.2.6 Loading Material

Loading material shall be steel strips, lead ingots, or other loading materials meeting the following requirements:

- (a) Individual steel strips shall have rounded or deburred edges, a maximum thickness of 3 mm (1/8 in.), a maximum width of 100 mm (4 in.), and a maximum length of 7.32 m (24 ft).

When load testing wire mesh cable tray with strips having a thickness of 3 mm (1/8 in.) and a maximum width of 100 mm (4 in.), the length of the strips shall not exceed 50% of the length of the test span. When full span strips are used, the maximum thickness shall be 1.6 mm (1/16 in.), and the maximum width shall be 100 mm (4 in.).

- (b) Five lead ingots, each weighing approximately 2.3 kg (5 lb), shall be interconnected across corners into a string of five ingots approximately 550 mm (22 in.) long. Individual ingots shall be hexagonal, approximately 75 mm (3 in.) in diameter, and 38 mm (1-1/2 in.) deep.
- (c) Other loading materials shall have a maximum weight of 4.5 kg (10 lb), a maximum width of 125 mm (5 in.), and a maximum length of 300 mm (12 in.).

5.2.7 Load Application

5.2.7.1 The load shall be applied in at least 10 increments that are approximately equal in weight.

5.2.7.2 Loading shall be uniformly distributed for the length and breadth of the specimen, except that the loading material shall not be closer than 13 mm (1/2 in.) nor further than 25 mm (1 in.) from the innermost elements of the sides. It shall be arranged across the tray with a minimum of 10 mm (3/8 in.) between stacks so that the loading material does not bridge transversely. All loading materials shall be placed between supports without overhanging. In multi-tier cable trays, the loading shall be uniformly distributed among the tiers.

5.2.7.3 For loading weight in trays with rungs, the bottom of the tray between supports may be covered with a flat sheet of No. 9 gauge, flattened expanded material not more than 900 mm (3 ft) long and with a wire hole size of 19 mm (3/4 in.), or a flat sheet of No. 16 gauge sheet steel not more than 900 mm (3 ft) long. The expanded metal or sheet steel (dunnage) shall not be fastened to the tray and shall be no closer than 13 mm (1/2 in.) to the side rails. The lengths shall not overlap by more than 50 mm (2 in.). The weight of expanded metal or sheet steel shall be added to the total weight of the loading material.

5.2.8 Loading to Destruction (Method A)

The total weight of the loading material on the cable tray, plus dunnage if used, prior to addition of the incremental weight that causes the destruction, shall be considered to be the destruction load. The rated load capacity of the cable tray shall be the destruction load divided by a safety factor of 1.5. For multi-tier trays, failure of any of the tiers shall be considered as failure of the whole cable tray.

The deflection shall be recorded for each additional incremental load. The maximum deflection reading shall be recorded for the rated load.

5.2.9 Loading to Residual Deflection (Method B)

5.2.9.1 Minimum Test Load

The minimum test load to be applied shall be determined in accordance with the following formula:

$$\text{Total minimum test load} = 1.5 \times L \times w$$

Where:

1.5 = safety factor

L = span length, m (ft)

w = rated load, kg/m (lb/ft)

5.2.9.2 Load Application

Each specimen shall first be loaded to 10% of the minimum test load. The vertical deflection of the tray shall be measured at three points along the line midway between the supports and at right angles to the longitudinal axis of the tray. The three points of measurement shall be under each side rail and at the center of the tray. In trays where there are no side rails, the three points of measurement shall be under the outer edges and under the center. This measurement shall be known as the initial deflection. The loading shall then be continued until all of the rated load is applied. The deflection shall be measured in the same manner as the initial deflection. The loading shall then be continued until the total minimum test load has been applied. The total load shall then be removed from the tray. After 15 min, the vertical deflection shall be measured in the same manner as previously used. This measurement shall be known as the residual deflection. The specimen may then be reloaded until it collapses, and the values of the load at collapse shall be recorded. This information concerning the load at collapse point is optional, but some users may require it to obtain product acceptance.

5.2.9.3 Measurement of Residual Deflection

The residual deflection at each point of measurement of the two specimens shall be averaged. Where a residual deflection for either specimen is equal to or exceeds 80% of the initial deflection and, in addition, deviates from the average by more than 10%, two more specimens shall be tested. The average of the three highest values at the point of measurement of the four specimens shall be regarded as the final result.

In multi-tier trays, the maximum deflection in any of the tiers shall be considered the maximum deflection of the whole tray.

5.3 INTERPOLATION OF TEST DATA—FOR USE WITH 5.2.8 (METHOD A) ONLY

When allowable load and deflection data are determined by the load test, destruction load capacity for span lengths less than the tested span shall be interpolated with the formula shown below. When interpolating in this manner, ensure that the rung strength is also sufficient to support the load.

$$w_2 = w_1 \times L_1^2 / L_2^2$$

Where:

w_2 = calculated load, kg/m (lb/ft)

w_1 = tested load, kg/m (lb/ft)

L_1 = tested span length, m (ft)

L_2 = new span length, m (ft)

5.4 RUNG LOAD CAPACITY (OPTIONAL)

5.4.1 General

If rung load capacity is to be specified by the manufacturer, the capacity shall be determined in accordance with Clauses 5.4.2 to 5.4.8.

5.4.2 Test Equipment

All load-bearing surfaces shall be flat, with edges rounded to a maximum radius of 3.2 mm (1/8 in.). An example of the application of the load is shown in Figure 2.

5.4.3 Test Specimen

For each rung design, two separate tests of the greatest rung length shall be made.

5.4.4 Span Length and Supports

Test spans shall be simple beam spans with free, unrestrained ends. Rungs shall not have side restraints. Each end of the specimen shall be supported by a flat steel bar at a span length as specified ± 38 mm (1-1/2 in.).

5.4.5 Orientation of Specimens

Specimens shall be tested in the horizontal position. The total length of the test specimen shall be the specified span length + 150 mm (6 in.) maximum. Any overhang shall be equally distributed beyond both supports.

5.4.6 Loading

All specimens shall be loaded to destruction. The loading shall be a concentrated load, applied to the 25 mm (1 in.) central length of the span.

5.4.7 Load Capacity

The maximum load applied to the rung shall be considered the destruction load capacity of the rung. The rated load capacity shall be the destruction load divided by a safety factor of 1.5.

NOTE—The rated load may be expressed as a uniform load by multiplying the concentrated load by a factor of two.

5.4.8 Interpolation of Rung Load Test Data

When the rated load data are determined by Clause 5.4.7, the rated load capacity for span lengths less than the tested span shall be interpolated with the following formula:

$$w_2 = w_1 \times L_1^2 / L_2^2$$

Where:

w_2 = calculated load, kg/m (lb/ft)

w_1 = tested load, kg/m (lb/ft)

L_1 = tested span length, m (ft)

L_2 = new span length, m (ft)

Section 6 PRODUCT MARKING, INFORMATION, AND INSTALLATION

NOTE—In Canada, there are two official languages, English and French. Annex A lists French translations of the markings specified in this Standard.

6.1 MARKING ON PRODUCT

6.1.1 Dimensions and measurements marked on the product shall include SI units. Markings expressed in inch-pound units shall be optional.

6.1.2 Each straight section of cable tray and each fitting shall be marked in a permanent and readily visible manner with the following:

- (a) the manufacturer's name, trademark, or other recognized symbol of identification;
- (b) the word "Ventilated" or "Nonventilated," as applicable;
- (c) the rated load/span as tested in accordance with Clause 5.2. Load classes as referenced in Table 1 and Table 2 may be marked in addition to, but not in place of, the rated load/span;
- (d) type of material, such as stainless steel (including the type), aluminum, etc; and, if carbon steel, Type 1 (hot-dip galvanized), Type 2 (mill galvanized), or Type 3 (electrodeposited zinc), as applicable. If the manufacturer's catalogue number marked on the product would readily lead the user to the required information published by the manufacturer, this marking is not mandatory;
- (e) when steel or aluminum cable tray systems are used as equipment grounding (or bonding) conductors, cable tray sections and fittings shall be marked to show the minimum cross-sectional area in accordance with the *CEC, Part I*, and the *NEC*; and
- (f) warning label that reads, "WARNING! DO NOT USE AS A WALKWAY, LADDER, OR SUPPORT FOR PERSONNEL. USE ONLY AS A MECHANICAL SUPPORT FOR CABLES, TUBING, AND RACEWAYS."

6.2 PRODUCT INFORMATION

The manufacturer shall provide, in a readily available form or with each shipment of cable tray, product information that shall include the following:

- (a) table or chart clearly indicating the maximum rated simple beam loading in kilograms/linear meter and/or pounds/linear foot, and the maximum recommended distance in meters and/or feet between supports for each loading; and
- (b) information on the alloys of aluminum or stainless steel, if such alloys are used.

6.3 CABLE TRAY INSTALLATION

Cable tray shall be installed in accordance with NEMA VE 2 or as recommended by the manufacturer.

Table 1
SPAN/LOAD CLASS DESIGNATION—USA
(See Clauses 4.8.1, 4.8.2 and 6.1.2 (c).)

Load, kg/m (lb/ft)	Span, m (ft)				
	1.5 (5)	2.4 (8)	3.0 (10)	3.7 (12)	6.0 (20)
37 (25)	5AA	8AA	10AA	12AA	20AA
74 (50)	5A	8A	10A	12A	20A
112 (75)	-	8B	-	12B	20B
149 (100)	-	8C	-	12C	20C

Note: These ratings are also used in Mexico

Table 2
SPAN/LOAD CLASS DESIGNATION—CANADA
See Clauses 4.8.1, 4.8.2 and 6.1.2(c)

Load kg/m (lb/ft)	Span, m (ft)						
	1.5 (5)	2.0	2.5	3.0 (10)	4.0	5.0	6.0 (20)
37 (25)				A			
45 (30)			A				
62 (42)		A					
67 (45)							D
82 (55)						D	
97 (65)				C			
99 (67)	A						
112 (75)							E
113 (76)					D		
119 (80)			C				
137 (92)						E	
164 (110)		C					
179 (120)				D			
189 (127)					E		
259 (174)	C						
299 (200)				E			

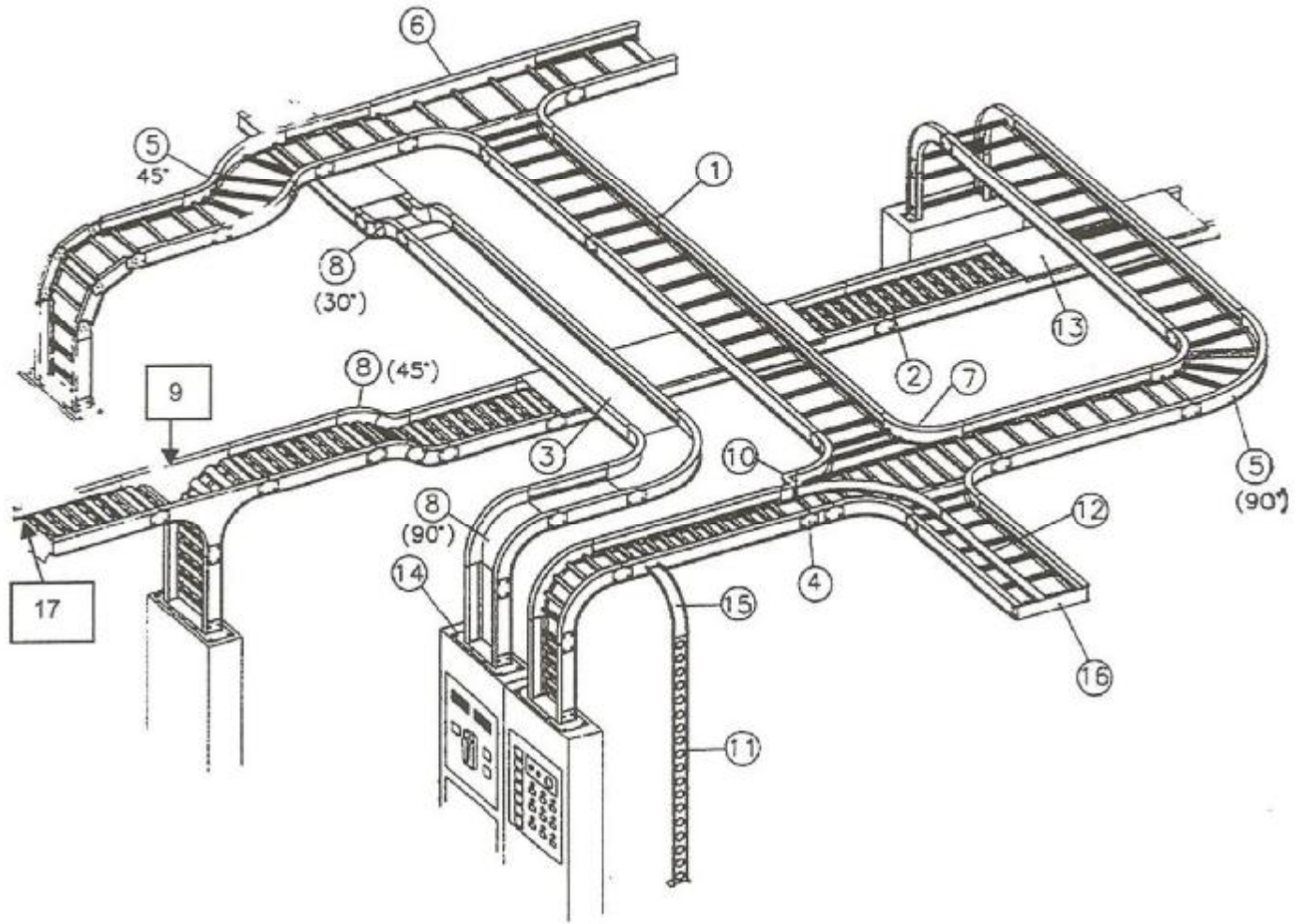

Legend:

- | | |
|-----------------------------|-----------------------------|
| 1 = Ladder cable tray | 10 = Reducer |
| 2 = Ventilated cable tray | 11 = Channel cable tray |
| 3 = Solid-bottom cable tray | 12 = Divider |
| 4 = Rigid connector | 13 = Cover |
| 5 = Horizontal elbow | 14 = Tray-to-box connector |
| 6 = Horizontal tee | 15 = Channel vertical elbow |
| 7 = Horizontal cross | 16 = Blind end |
| 8 = Vertical elbow | 17 = Dropout |
| 9 = Vertical tee | |

Figure 1
ILLUSTRATION OF SELECTED DEFINITIONS
 (See Clause 2.1)

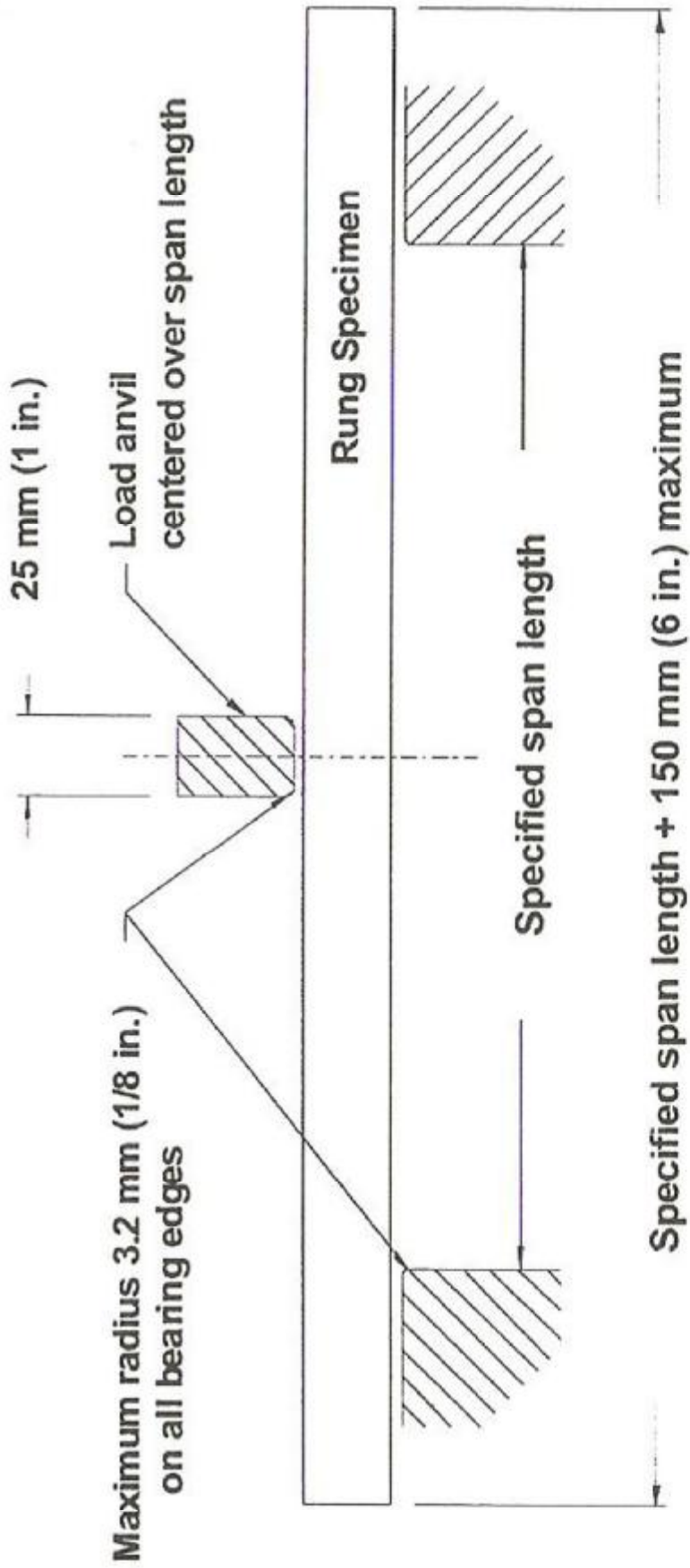

Figure 2
APPLICATION OF LOAD—RUNG LOAD CAPACITY
 (See Clause 5.4.2.)

Annex A
MARKINGS—FRENCH TRANSLATIONS
(informative)

NOTE—This Annex is not a mandatory part of this Standard.

The following are acceptable French translations of required markings (see Clause 6):

Clause	English	French
6.1.2 (b)	Ventilated	Ajourés
6.1.2 (b)	Nonventilated	Non ajourés
6.1.2 (f)	WARNING! DO NOT USE AS A WALKWAY, LADDER, OR SUPPORT FOR PERSONNEL. USE ONLY AS A MECHANICAL SUPPORT FOR CABLES, TUBING, AND RACEWAYS.	AVERTISSEMENT! CECI N'EST PAS UNE PASSERELLE, NI UNE ÉCHELLE, NI UNE APPUI POUR LE PERSONNEL. UTILISER UNIQUEMENT POUR SUPPORTER DES CÂBLES, DES TUBES ET DES CANALISATIONS.

NEMA Standards Publication VE 2-2000

Cable Tray Installation Guidelines

Published by:

National Electrical Manufacturers Association
1300 North 17th Street
Rosslyn, VA 22209

Approved by:

Cable Tray Institute
1300 North 17th Street
Rosslyn, VA 22209

© Copyright 2001 by the National Electrical Manufacturers Association. All rights including translation into other languages, reserved under the Universal Copyright Convention, the Berne Convention for the Protection of Literary and Artistic Works, and the International and Pan American Copyright Conventions.

Contents

	Foreword	iii
	Scope	iv
Section 1	GENERAL	1
Section 2	RECEIVING AND UNLOADING	3
Section 3	STORAGE	5
Section 4	INSTALLATION	7
4.1	Common Tools for Installation	7
4.2	Support Installation	7
4.3	Straight Section Installation	16
4.4	Fittings Installation	24
4.5	Field Modifications	26
4.6	Accessories	29
4.7	Grounding and Bonding	34
Section 5	INSTALLATION OF CABLE	39
5.1	General	39
5.2	Handling and Storage	39
5.3	Cable Tray Preparation	39
5.4	Cable Pulling Considerations	39
5.5	Pulling the Cable	40
5.6	Fastening of Cables	41
5.7	Protecting Installed Cable	42
Section 6	MAINTENANCE	43
6.1	Inspection	43
6.2	Inactive or Dead Cables	43
6.3	Adding Cables	43
Appendix A	TYPICAL CABLE TRAY TYPES	45

Foreword

For Cable Tray Installers—This publication is intended as a practical guide for the proper installation of cable tray systems. Cable tray systems design shall comply with NEC Article 318, NEMA VE 1, and NEMA FG 1 and follow safe work practices as described in NFPA 70E.

These guidelines and information do not intend to cover all details or variations in cable tray systems nor provide for every possible installation contingency.

Construction Experience—It is recommended that the work described be performed by qualified persons familiar with standard electrical construction practices, electrical equipment, and safety of electrical wiring systems.

These guidelines will be useful to engineers, contractors, and maintenance personnel. This publication will be reviewed periodically with the purpose of updating it to reflect advancing technology and construction techniques. Please address any comments or questions to:

Vice President, Engineering
National Electrical Manufacturers Association
1300 North 17th Street
Suite 1874
Rosslyn, VA 22209

or

Technical Director
Cable Tray Institute
4101 Lake Boone Trail
Suite 201
Raleigh, NC 27607-6518

This is the second edition of this publication.

This standards publication was developed by the NEMA Metal Cable Tray and Nonmetallic Cable Tray Sections. Section approval of the standard does not necessarily imply that all section members voted for its approval or participated in its development. At the time it was approved, the Metal Cable Tray and Nonmetallic Cable Tray Sections were composed of the following members:

Champion Fiberglass—Spring, TX
Chalfant Manufacturing Company—Cleveland, OH
Cooper B-Line—Highland, IL
Enduro Fiberglass Systems, Inc.—Houston, TX
GS Metals Corporation—Pinckneyville, IL
MP Husky Corporation—Greenville, SC
P-W Industries, Inc.—Atlanta, GA
Seasafe, Inc.—Lafayette, LA
Square D Company—Oxford, OH
Thomas & Betts Corporation—Memphis, TN
T. J. Cope, Inc.—Wayne, MI
Tex Tray Inc.—Houston, TX
The Wiremold Company—West Hartford, CT

DISCLAIMER

The standards or guidelines presented in a NEMA Standards Publication are considered technically sound at the time they are approved for publication. They are not a substitute for a product seller's or user's own judgment with respect to the particular product referenced in the standard or guideline, and NEMA does not undertake to guarantee the performance of any individual manufacturer's products by virtue of this standard or guide. Thus, NEMA expressly disclaims any responsibility for damages arising from the use, application, or reliance by others on the information contained in these standards or guidelines.

SCOPE

This publication addresses shipping, handling, storing, and installing cable tray systems. Information on maintenance and system modification is also provided.

Abbreviations used in this standard are as follows:

- "in" denotes inch;
- "ft" denotes foot;
- "lb" denotes pound;
- "mm" denotes millimeter;
- "kg" denotes kilogram;
- "m" denotes meter;
- "N" denotes newtons;
- "°F" denotes degree Fahrenheit;
- "°C" denotes degree Celsius.

Section 1 GENERAL

WARNING!—Do not use a cable tray as a walkway, ladder, or support for people; cable tray is a mechanical support system for cables and raceways. Using cable trays as walkways can cause personal injury and also damage cable tray and installed cables.

Hazardous voltages in electrical equipment can cause severe personal injury or death. Safety related work practices, as described in NFPA 70E, Part 11, should be followed at all times.

The performance of a cable tray wiring system is dependent on its proper installation, including supports and cables. Neglecting installation and maintenance guidelines may lead to personal injury as well as damage to property.

Installation and maintenance of cable tray wiring systems shall be conducted only by qualified personnel. For the purposes of this guideline, a qualified person is one who is familiar with electrical construction. In addition, the person is:

- Trained and authorized to test, energize, clear, ground, tag, and lock out circuits in accordance with established safety practices.

- Trained in the proper care and use of protective equipment such as insulated rubber gloves, hard hat, safety glasses or face shields, dust mask, and flash resistant clothing in accordance with established safety practices.

Section 2 RECEIVING AND UNLOADING

Cable tray is generally bundled and shipped via motor freight, except for export shipments that could be crated or loaded in containers. Accessories and small components are boxed and often skidded.

Cable tray can be shipped via enclosed van, trailer, or flat bed trailer. Van trailers are normally used for less than truckload (LTL) shipments. This method of shipment is most common and cost effective and offers maximum protection from the weather during shipment. LTL shipments should be hand unloaded unless provisions have been made with the cable tray manufacturer for forklift unloading.

Flat bed trailers are often used for full truckload shipments and when customers want side forklift unloading or sling unloading by crane. (Special care must be exercised using slings so cable tray is not crushed from the improper location and lifting by sling.)

CORRECT

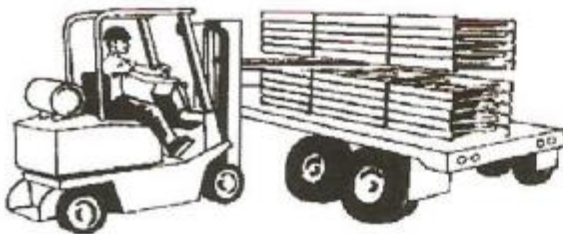

NOT CORRECT



*Except when utilizing extended forks for skidded bundles

Small to medium size orders less than 2000 ft. (600 m) are generally shipped via common carrier - LTL in enclosed vans.

If hand unloaded, workers should wear gloves.

To prevent damage to cable tray, never pull cable tray from truck trailer by chaining to bottom rung and dragging out of trailer.

CORRECT

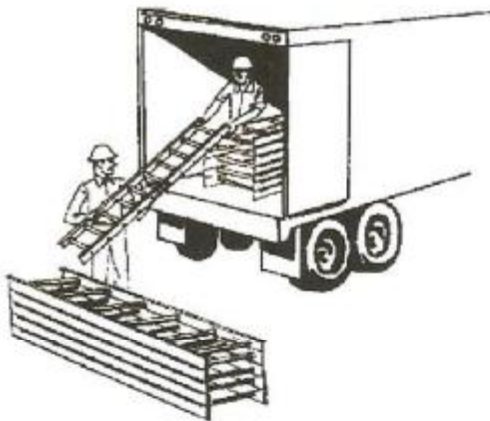

NOT CORRECT

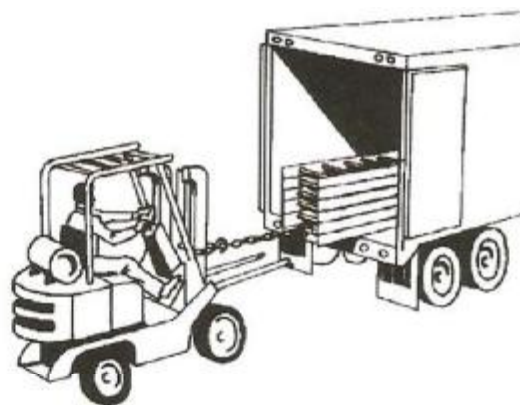

Inventory all items immediately after unloading, using the manufacturer's packing list. Note on the bill of lading any shortage or shipping damage for filing freight claim.

Section 3 STORAGE

Hot dipped galvanized after fabrication (H.D.G.A.F.) (see ASTM A 123) steel, aluminum, and stainless steel cable tray and fiberglass or other non-metallic cable tray can be stored outside without cover, but should be loosely stacked, elevated off the ground, and ventilated to prevent storage stain. If appearance is important, cable tray should be stored indoors to prevent water or other foreign materials from staining or adhering to cable tray.

Mill galvanized (see ASTM A 653) or electro-galvanized (see ASTM B 633) cable tray must be protected or stored in a well ventilated, dry location.

Bare steel cable tray should receive a protective coating as soon as possible to prevent surface rust.

PVC or painted cable tray should be protected and stored indoors if possible. Cable tray must be protected from scratching and marring of finish.

Small accessories should be stored to prevent loss.

Cable tray should be stored away from high traffic areas. Cable tray should be stacked by width and type.

Section 4 INSTALLATION

For Cable Tray Installers—This publication is intended as a practical guide for the proper installation of cable tray systems. Cable tray system design shall comply with NEC Article 318, NEMA VE 1, and NEMA FG 1, and shall follow safe work practices as described in NFPA 70E.

These instructions and information do not intend to cover all details or variations in cable tray systems nor provide for every possible installation contingency.

Construction Experience—It is recommended that the work described be performed by qualified persons familiar with standard electrical construction practices, electrical equipment, and safety of electrical wiring systems.

4.1 COMMON TOOLS FOR INSTALLATION

The following tools are commonly used for installation of cable tray:

- Metal cutting saw
- Touch-up material
- Screwdriver
- Drill with bits
- File
- Open end wrench
- Nylon cord or laser
- Sealant for cut edges (Fiberglass)
- Cutting Saw (Fiberglass) Carbide or Diamond Tipped
- Leveling device
- Tape measure
- Square
- C-clamp
- Torque wrench
- Ratchet wrench
- Offset Bolt cutters (Wire mesh)
- Dust Mask (Fiberglass)
- Appropriate safety equipment

4.2 SUPPORT INSTALLATION

Caution! Do not cut or drill structural building members (e.g. I-beams) without approval by the general contractor.

In order to install the cable tray supports, first find the required elevation from the floor to the bottom of the cable tray and establish a level line with a laser or a nylon string. A string works well because it can be used to align the threaded rods on one side of a trapeze and find the tops of the supports.

In order to speed the process of installing the trapeze hangers, some nuts may be pre-threaded onto the threaded rod to the approximate location where the nut will be needed. One method for pre-threading the nuts is to put the nuts onto the end of a piece of threaded rod, attach a drill to the threaded rod, and run the nuts up the rod holding onto them with an open-end wrench.

NOTE—Nonmetallic supports and hardware may require special load bearing considerations due to material composition and application temperature. Consult the cable tray manufacturer for recommended practices.

4.2.1 Cable Tray Supports

Caution! Supports for cable trays should provide strength and working load capabilities sufficient to meet the load requirement of the cable tray wiring system. Consideration should be given to the loads associated with future cable additions (see section 6.3) or any other additional loads applied to the cable tray system or the cable trays support system.

NOTE—Nonmetallic supports and hardware may require special load bearing considerations due to material composition and application temperature.

NOTE—Special consideration may be required for center-supported systems considering eccentric loading.

4.2.1.1 Trapeze Type (See Figures 4.1A through 4.1G.)

To install:

- a. Thread nuts onto threaded rod approximately 2 in. (50 mm) above desired location for bottom of cable tray.
- b. Slide on square washers followed by cross member and second set of square washers.
- c. Thread second set of nuts onto threaded rod.
- d. Move cross member so the top surface is located where bottom of cable tray run will be located.
- e. Move second set of nuts up threaded rod until cross member is reached and held in place.
- f. Make sure cross member is level, then move first set of nuts down threaded rod until cross member is secured in place.

In most cases, hold-down guide clamps may be mounted on either the inside or outside of the cable tray side rail. When installed on the inside of the cable tray, the clamp and/or attaching hardware should not extend above the rung.

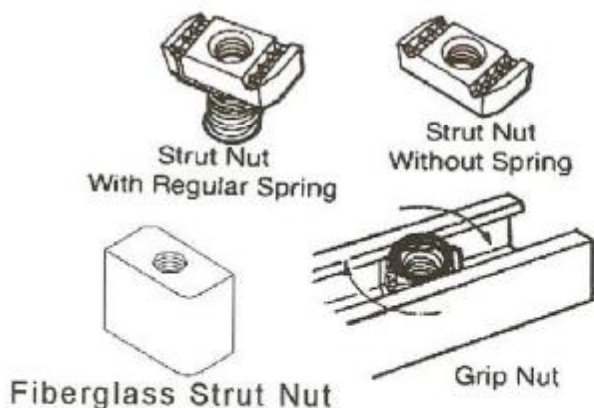

**Figure 4.1A
STRUT NUT**

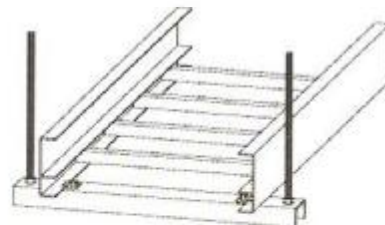

**Figure 4.1B
C-CHANNEL SUPPORT**

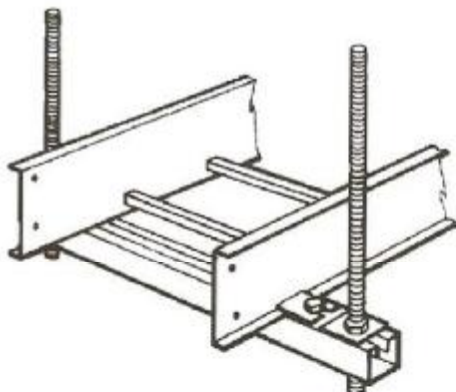

**Figure 4.1C
STRUT SUPPORT**

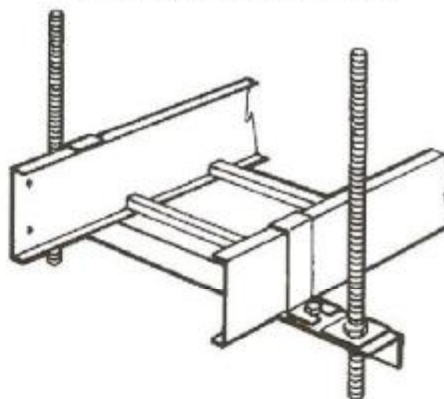

**Figure 4.1D
ANGLE IRON SUPPORT**

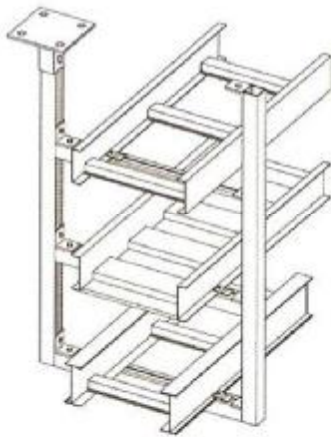

Figure 4.1E
TYPICAL STRUT SUPPORT INSTALLATION

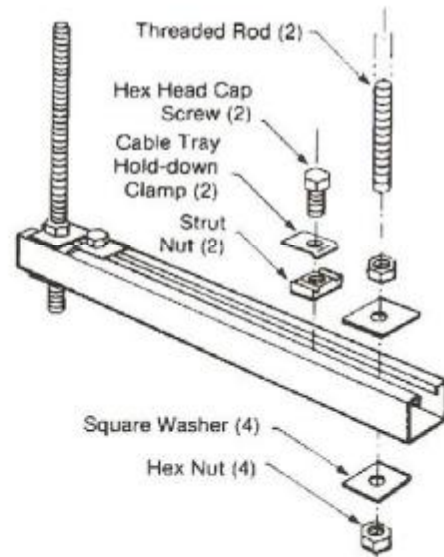

Figure 4.1F
STRUT-EXPLODED VIEW

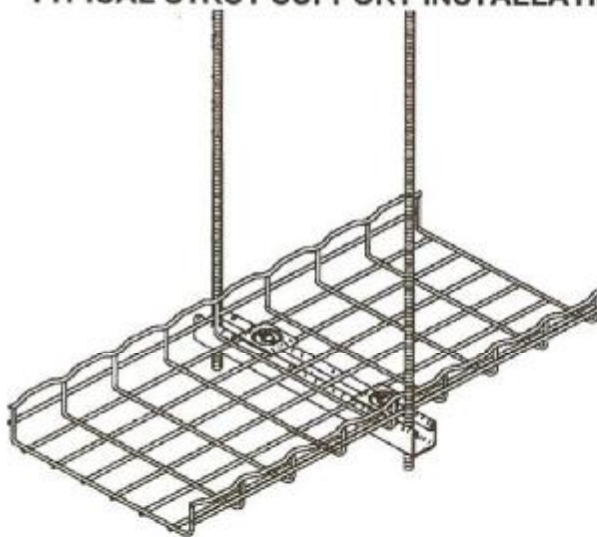

Figure 4.1G
HOLD DOWNS

4.2.1.2 Hanger Rod Clamp (See Figures 4.2A through 4.2E.)

To install:

- Thread nuts onto threaded rod approximately 9 in. (225 mm) above desired location for bottom of cable tray.
- Place clamp around side rail of cable tray.
- Lift entire cable tray section onto threaded rod running threaded rod through holes in clamps.
- Thread a second set of nuts onto threaded rod moving them up until bottom of cable tray reaches desired location.
- Move first set of nuts down threaded rod and secure clamps in place.

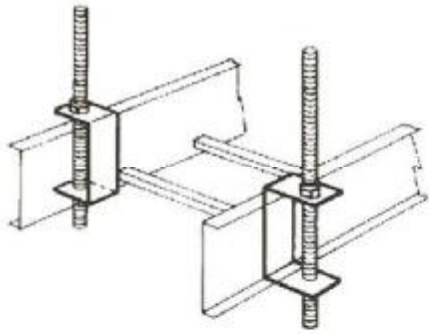

Figure 4.2A
SINGLE CABLE TRAY HANGER

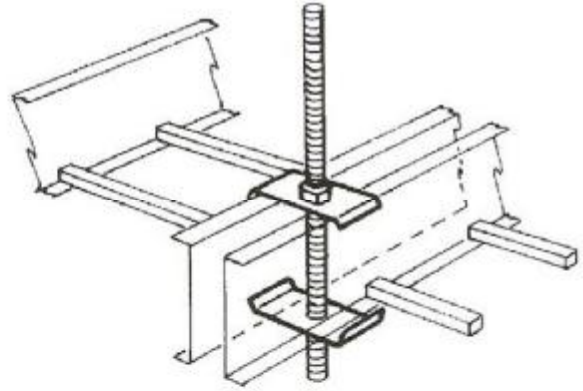

Figure 4.2B
DOUBLE CABLE TRAY HANGER

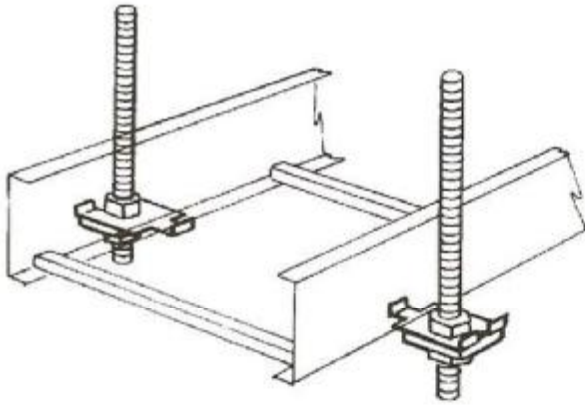

Figure 4.2C
SINGLE CABLE TRAY HANGER

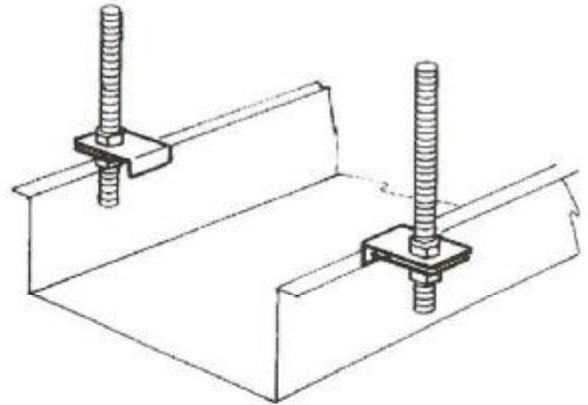

Figure 4.2D
SINGLE CABLE TRAY HANGER

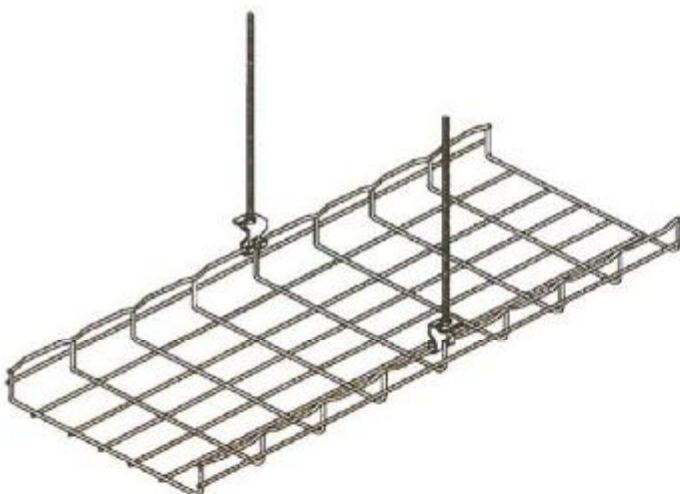

Figure 4.2E
SINGLE CABLE TRAY HANGER

4.2.1.3 Center Hung Support (See Figures 4.3A and 4.3B)

To install:

- a. Thread nut onto threaded rod approximately 9 in. (225 mm) above desired location for bottom of cable tray.
- b. Slide washer and support onto threaded rod with upright tube going through center of cable tray section needing support.
- c. Place a square washer on threaded rod and thread on second nut.
- d. Move cross member so its top surface is located at the place where bottom of cable tray run will be located.
- e. Move second nut up threaded rod until it reaches cross member and holds it in place.
- f. Move first nut down threaded rod until it secures cross member in place.

In most cases, hold-down/guide clamps may be mounted on either the inside or outside of the cable tray. When installed on the inside of the cable tray, the clamp and/or attaching hardware should not extend into the cable pathway.

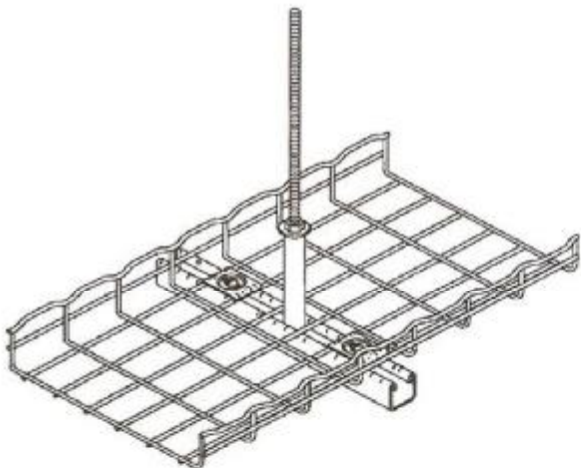

Figure 4.3A
CENTER HANGER SUPPORT

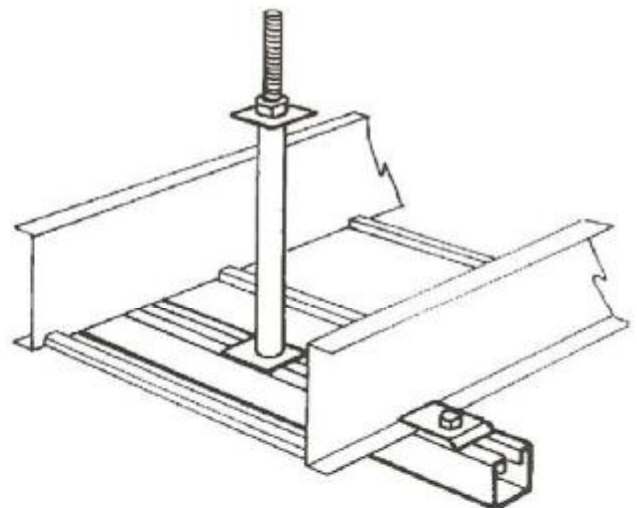

Figure 4.3B
CENTER HANGER SUPPORT

4.2.1.4 Single Channel Cable Tray Hanger (See Figure 4.4)

To install:

- a. Thread nut onto threaded rod to height required.
- b. Place hanger on threaded rod and follow with one nut.
- c. Run nut up threaded rod until bottom of hanger is at desired height.
- d. Run top nut down to tighten.
- e. Place channel on hanger and secure in place as necessary.

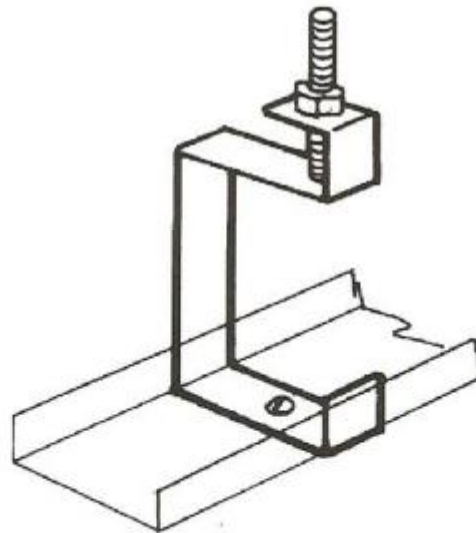

Figure 4.4
SINGLE CHANNEL HANGER

4.2.1.5 Double Channel Cable Tray Hanger (See Figure 4.5.)

To install:

- a. Thread nut onto threaded rod to height required.
- b. Place hanger on threaded rod and follow with one nut.
- c. Run nut up threaded rod until bottom of hanger is at desired height.
- d. Run top nut down to tighten.
- e. Place channels on hanger and secure in place as necessary.

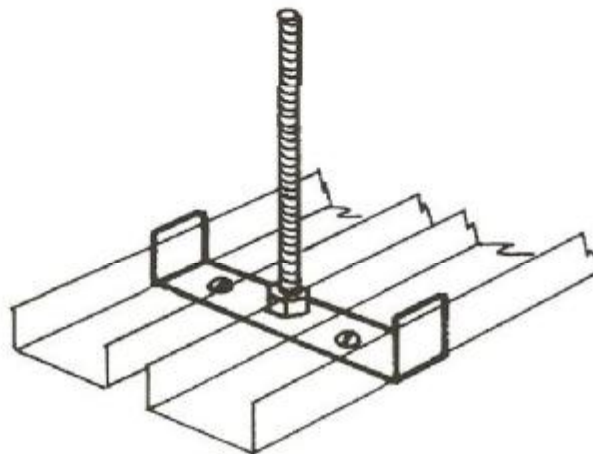

Figure 4.5
DOUBLE CHANNEL HANGER

4.2.1.6 Single Rail Cable Tray Hangers (See Figures 4.6A through 4.6C)

To install:

- a. Thread nut onto threaded rod to height required.
- b. Place hanger or cable tray on threaded rod and follow with one nut.
- c. Run nut up threaded rod until bottom of hanger or cable tray is at desired height.
- d. Run top nut down to tighten.
- e. Place cable tray in hanger and secure in place as necessary.

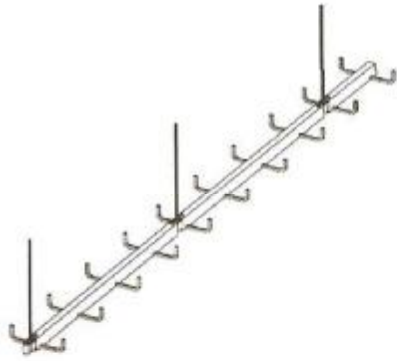

Figure 4.6A
MULTIPLE SPLICE SUPPORT

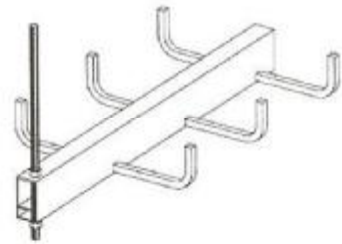

Figure 4.6B
ROD THROUGH SPINE HANGER

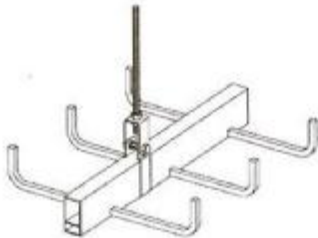

Figure 4.6C
CLEVIS HANGER

4.2.2 Wall and Cantilever Brackets (See Figures 4.7A through 4.7E.)

Secure the brackets to the structure making sure they are level and aligned with each other.

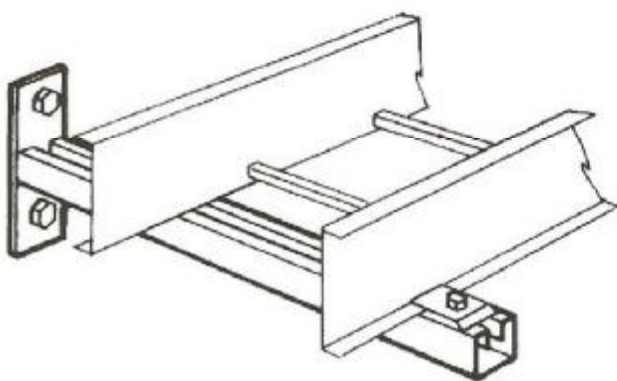

Figure 4.7A
SINGLE STRUT CANTILEVER BRACKET

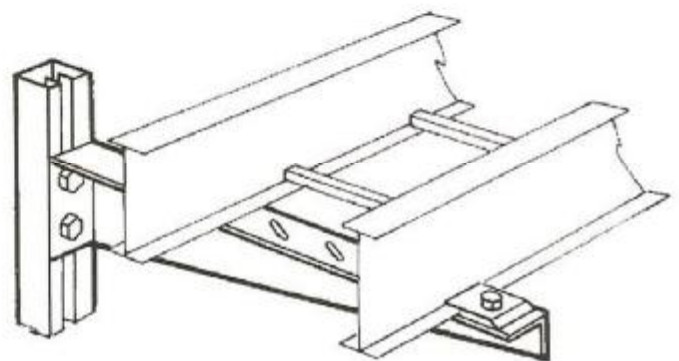

Figure 4.7B
GUSSET CANTILEVER BRACKET

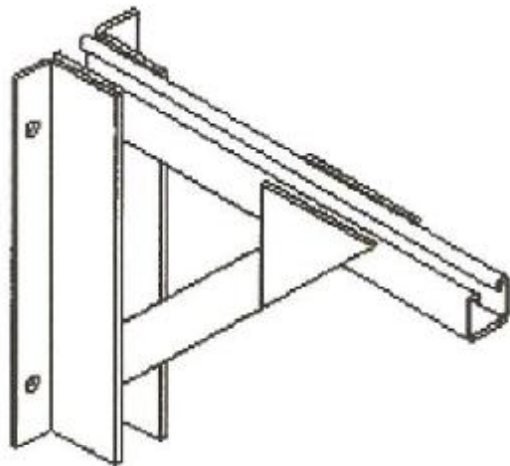

Figure 4.7C
FIBERGLASS CANTILEVER BRACKET

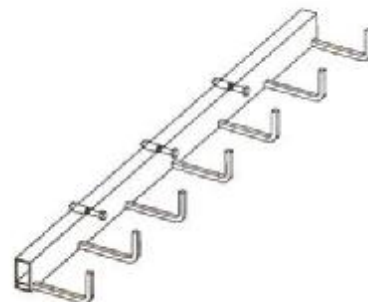

Figure 4.7D
SINGLE RAIL DIRECT WALL MOUNT



Figure 4.7E
SINGLE RAIL CLAMP WALL MOUNT

4.2.3 Floor and Roof Installations (See Figures 4.8A through 4.8C.)

Cable tray should not be laid directly on the floor or roof. It should be mounted far enough off the floor or roof to allow the cables to exit through the bottom of the cable tray. If strut is used for this purpose, mount the strut directly to the floor or roof and attach the cable tray to the strut using hold-down clamps and/or guide clamps.

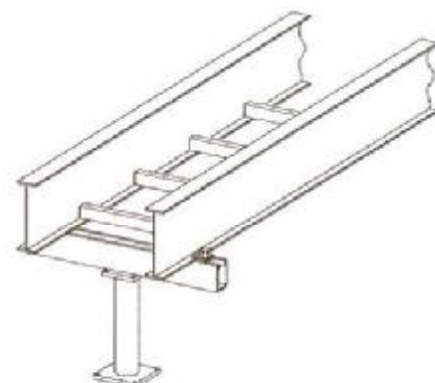

Figure 4.8A
ELEVATED STRUT TYPE SUPPORT

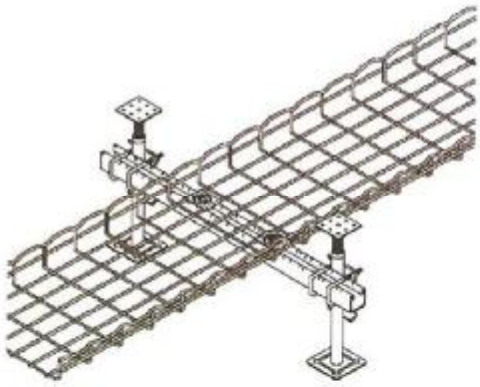

Figure 4.8B
UNDERFLOOR SUPPORT ATTACHED
TO FLOOR PEDESTALS



Figure 4.8C
SINGLE RAIL FLOOR SUPPORT

4.2.4 Vertical Applications (See Figures 4.9A through 4.9D.)



Figure 4.9A
VERTICAL THREADED ROD SUPPORT

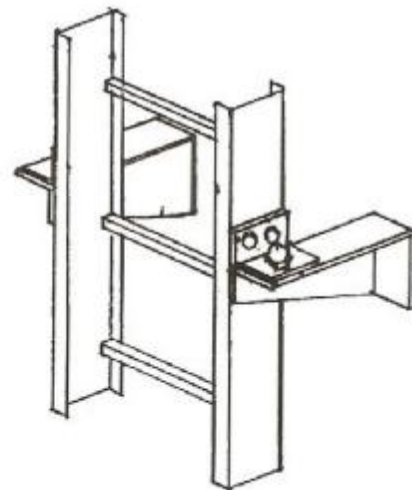

Figure 4.9B
VERTICAL GUSSET CANTILEVER SUPPORT

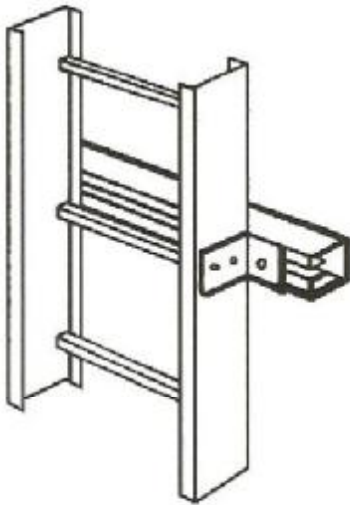

Figure 4.9C
VERTICAL STRUT SUPPORT

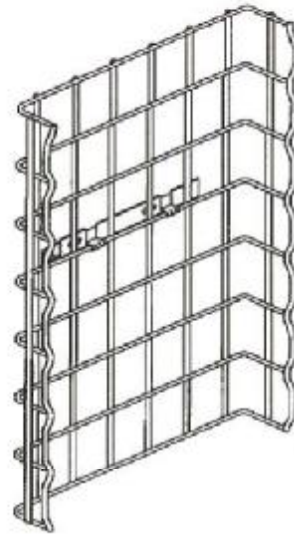

Figure 4.9D
VERTICAL WALL MOUNT

4.3 STRAIGHT SECTION INSTALLATION

Use the torque data below for fasteners. Follow manufacturer's recommendations for nonmetallic or nonferrous fasteners. Torque values do not apply for hollow sections such as tubes. Consult the manufacturer for recommendations.

Table 4-1
FASTENER TORQUE

Inch: GRD. 2 UNC		Metric: Class 5.8	
Size	Ft-Lbs	Size	N-m
1/4 – 20	4-6	M8 x 1.25	14-16
3/8 – 16	17-23	M10 x 1.5	26-33
1/2 – 13	42-56	M12 x 1.78	45-58

NOTES

- 1 Threads are not lubricated.
- 2 Fastener Finishes: zinc plated, cadmium plated, and stainless steel.

4.3.1 Straight Section Position

After the supports are in place, the installation of the cable tray can begin at any place that is convenient. It is not necessary to start at one end of the run. It is ideal to lay out the system so that splice joints fall between the support and the quarter point (Figure 4.10A). This maximizes the rigidity of the cable tray. For example, when installing a 12-foot long section, a support spacing of 12 ft. (3.7 m) will cause the splice joints to fall at the same position every time.

For single rail cable tray see Figures 4.6A, 4.7D, and 4.7E.

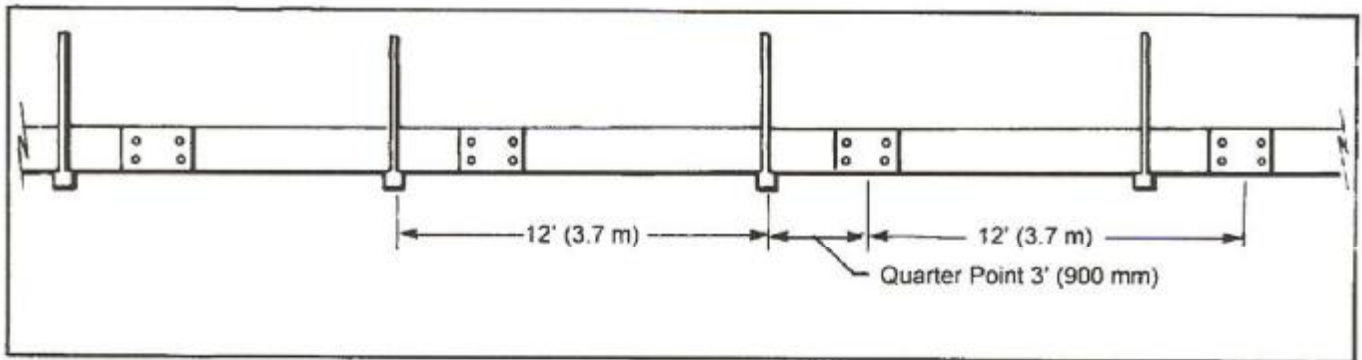

Figure 4.10A
CABLE TRAY SUPPORT LOCATIONS

To begin, place a straight section across two supports so that the ends of the section are not directly on the support (Figure 4.10B). If the support span is equal to the length of the straight sections, bolt two pieces together for this step (Figure 4.10C). **The support span should not be greater than the straight section length or as recommended by the manufacturer, to ensure no more than one splice is located between supports.** As a general practice, avoid placing splice plates over supports or at mid-span. However, certain cable tray systems (see Figure 4.6A) and certain splice designs allow for random splice location. See manufacturer for details.



Figure 4.10B
CABLE TRAY INSTALLATION

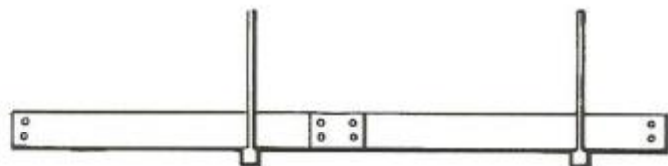

Figure 4.10C
CABLE TRAY INSTALLATION

Place the next straight section across the next support, and attach it to the previous section with a pair of splice plates and hardware. Splice plates should be placed on the *outside* of the cable tray, unless otherwise specified by the manufacturer, with the bolt heads on the *inside* of the cable tray (Figure 4.11).

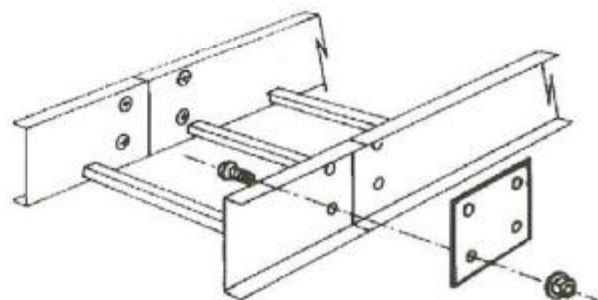

Figure 4.11
SPLICE PLATE ATTACHMENT

4.3.2 Expansion Splice Plates

It is important that thermal contraction and expansion be considered when installing cable tray systems. The length of the straight cable tray run and the temperature differential govern the number of expansion splice plates required (see Figure 4.12 and Table 4-2).

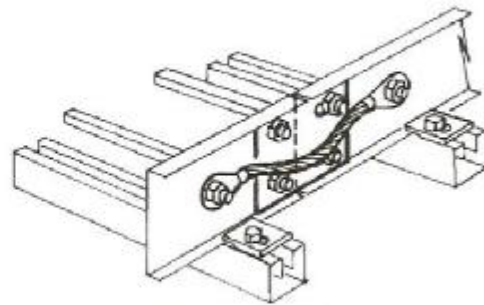

Figure 4.12
EXPANSION SPLICE PLATE ATTACHMENT

*Bonding jumper not required for fiberglass cable tray systems

Table 4-2
MAXIMUM SPACING BETWEEN EXPANSION JOINTS
THAT PROVIDE FOR ONE INCH MOVEMENT**

Temperature Differential		Steel		Aluminum		Fiberglass	
°F	(°C)	feet	(m)	feet	(m)	feet	(m)
25	(14)	512	(156)	260	(79)	667	(203)
50	(28)	256	(78)	130	(40)	333	(102)
75	(42)	171	(52)	87	(27)	222	(68)
100	(56)	128	(39)	65	(20)	167	(51)
125	(70)	102	(31)	52	(16)	133	(41)
150	(83)	85	(26)	43	(13)	111	(34)
175	(97)	73	(22)	37	(11)	95	(29)

* The temperature differential is the difference in the temperature between the hottest and coldest days of the year.

** For designs that provide for 5/8 in. (16 mm) movement (typically non-metallic), multiply maximum spacing between expansion joints by 0.625.

The cable tray should be anchored at the support nearest to its midpoint between the expansion splice plates and secured by expansion guides at all other support locations (see Figure 4.13A). The cable tray should be permitted longitudinal movement in both directions from that fixed point.



Figure 4.13A
HOLD DOWN AND GUIDE CLAMP LOCATIONS

Accurate gap setting at the time of installation is necessary for the proper operation of the expansion splice plates. The following procedure should assist the installer in determining the correct gap (see Figure 4.13B):

- a. Plot the highest expected temperature on the maximum temperature line.
Example Value = 100°F (38°C)
- b. Plot the lowest expected temperature on the minimum temperature line.

Example Value = -28°F (-33°C)

- c. Draw a line between the maximum and minimum points.
- d. Plot the temperature at the time of installation to determine the gap setting.
Example Value = 3/8 in. (9.5 mm), 50°F (10°C).

Special hardware is supplied with expansion splice plates. The nuts may have a stopping device (plastic stop nut). **Important**—for plastic stop nut designs, tighten hardware, and then loosen 1/2 turn. For other types of hardware, follow manufacturer's instructions.

Metal Cable tray expansion joints require bonding for electrical continuity. Refer to Section 4.7 for bonding jumper installation (see Figure 4.12).

Supports should be located within 2 ft. (600 mm) of each side of expansion splice plates.

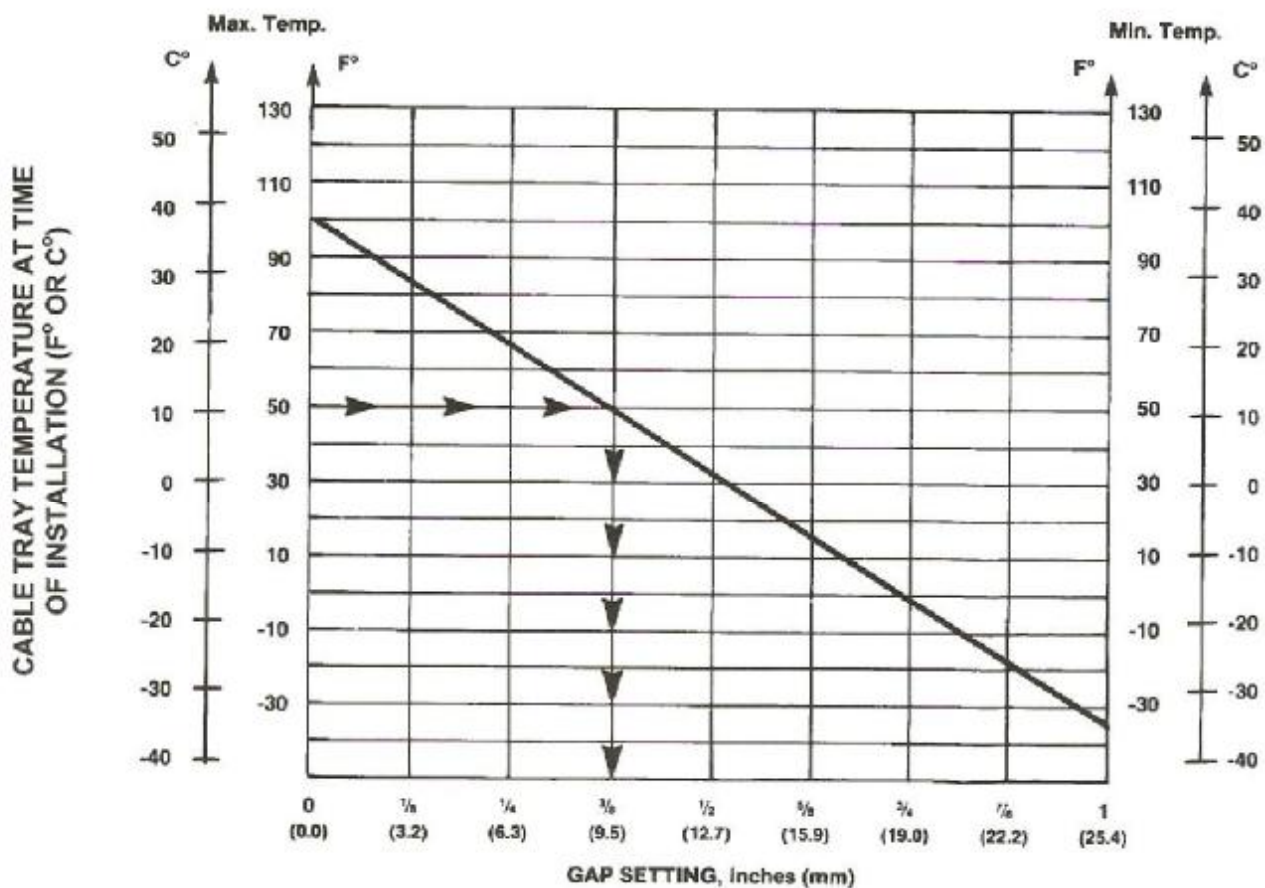

Figure 4.13B
GAP SETTING OF EXPANSION SPLICE PLATE
1 in. (25.4 mm) Gap Maximum*

*For designs using 5/8 in. (15.9 mm) maximum gap (typically non-metallic), multiply gap setting by 0.625.

4.3.3 Vertical Adjustable Splice Plates (See Figures 4.14A and 4.14B.)

For changes in vertical direction not requiring a radius, vertical adjustable splice plates can be used. Supports should be located within 2 ft. (600 mm) of each side of vertical adjustable splice plates.

- a. Position splice halves so that offsets adjust for material thickness and fasten with nut and bolt using hole (A).

- b. Attach to positioned cable tray sections which will set needed angle.
- c. Drill to complete hole (B). Figure 4.14A only.
- d. Insert and tighten all hardware.

For metal cable tray, bonding jumpers are required for electrical continuity, unless the splice plates meet the electrical continuity requirements of NEMA Standard VE 1. (Refer to Section 4.7 - Grounding)

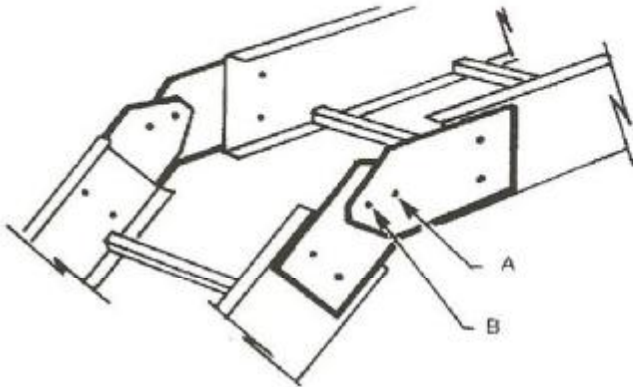

Figure 4.14A
TWO BOLT VERTICAL ADJUSTABLE
SPLICE PLATES

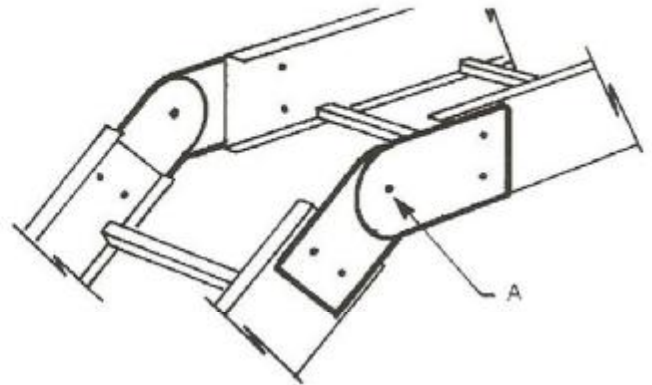

Figure 4.14B
SINGLE BOLT VERTICAL ADJUSTABLE
SPLICE PLATES

4.3.4 Horizontal Adjustable Splice Plates (See Figure 4.15.)

For changes in horizontal direction not requiring a radius, horizontal adjustable splice plates can be used. Supports should be located within 2 ft. (600 mm) of each side of horizontal adjustable splice plates.

- a. Connect inside connector (short piece) and position cable tray sections to set angle.
- b. Position outside connector locating hinge at mid-point.
- c. Drill required holes and install and tighten all hardware.

For metal cable tray, bonding jumpers are required for electrical continuity unless the splice plates meet the electrical continuity requirements of NEMA Standard VE 1 (Refer to Section 4.7 - Grounding).

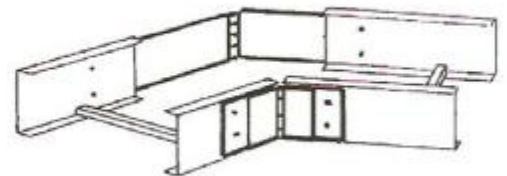

Figure 4.15
HORIZONTAL ADJUSTABLE
SPLICE PLATES

4.3.5 Cable Tray-to-Box or Floor Splice Plates (See Figures 4.16A and 4.16B)

For termination of cable tray system to equipment or structures:

Cable trays and/or cable penetrations through partitions, walls, floors, and ceilings often require special fire rating or environmental concerns and should be handled in accordance with NEC® Articles 318 and 300.

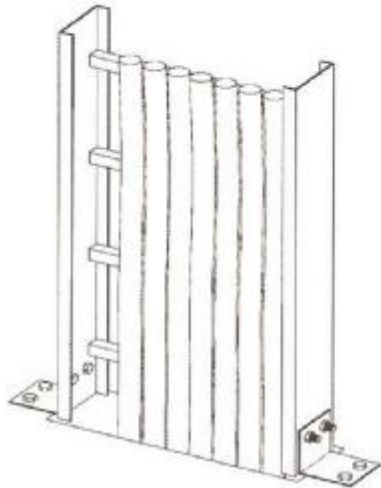

Figure 4.16A
CABLE TRAY-TO-BOX/FLOOR SPLICE PLATES

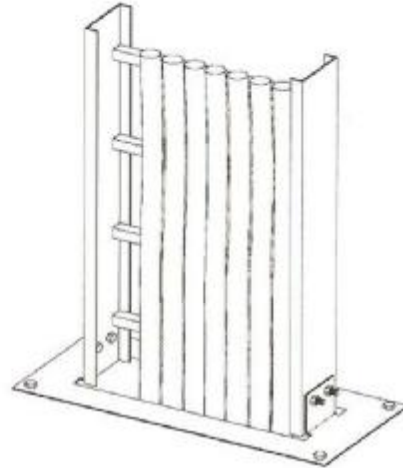

Figure 4.16B
CABLE TRAY-TO-BOX CONNECTOR

4.3.6 Offset Reducing Splice Plates (See Figure 4.17.)

For immediate width changes, use offset reducing splice plates. Supports should be located within 2 ft. (600 mm) of each side of offset reducing splice plates.

- a. Use an offset reducing splice plate with a standard splice plate to form an offset reduction.
- b. Use a pair of offset reducing splice plates to form a straight reduction.

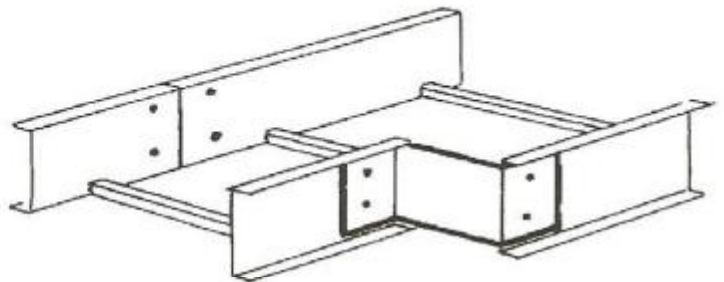

Figure 4.17
OFFSET REDUCING SPLICE PLATE

4.3.7 Vertical Support Plates (See Figure 4.18.)

Use vertical support splice plates for additional support of extended vertical runs. (See Section 4.2.4)



**Figure 4.18
VERTICAL SUPPORT PLATES**

4.3.8 Step-down Splice Plates (See Figure 4.19.)

Use step-down splice plates when connecting cable trays of different heights.

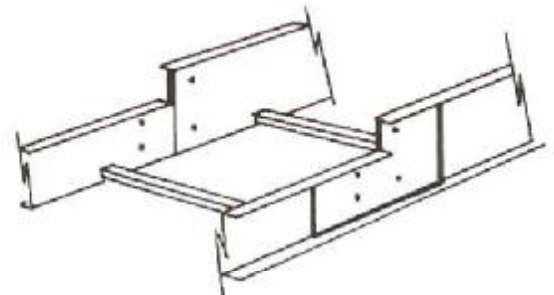

**Figure 4.19
STEP-DOWN SPLICE PLATES**

4.3.9 End Plates (See Figure 4.20.)

For dead-end closure indicating termination of cable tray run use end plates.

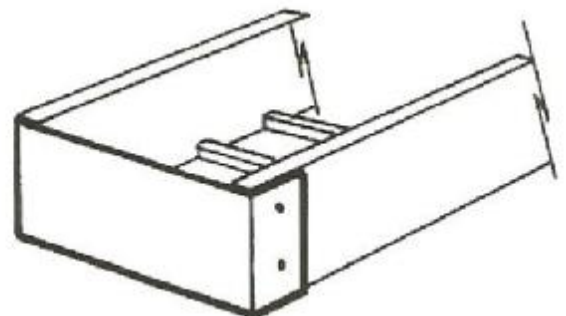

**Figure 4.20
END PLATE**

4.3.10 Single Rail Cable Tray Fitting Connectors (See Figures 4.21A through 4.21D)

Single rail cable trays typically use connector plates in lieu of radius fittings.

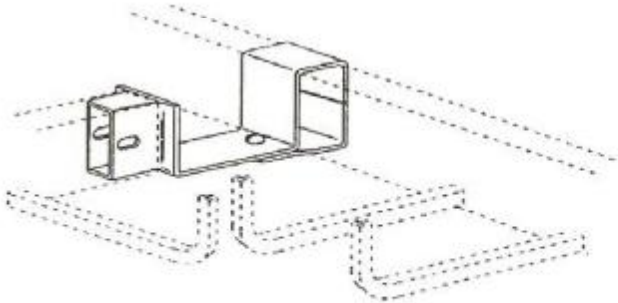

Figure 4.21A
HORIZONTAL TEE OR 90° CONNECTOR

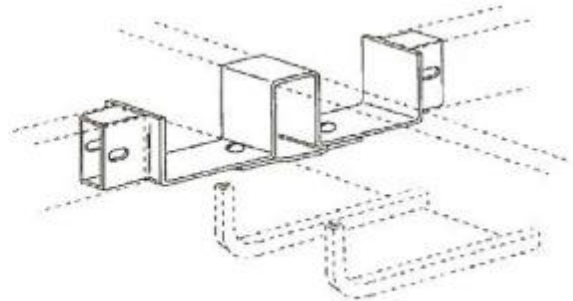

Figure 4.21B
HORIZONTAL CROSS CONNECTOR

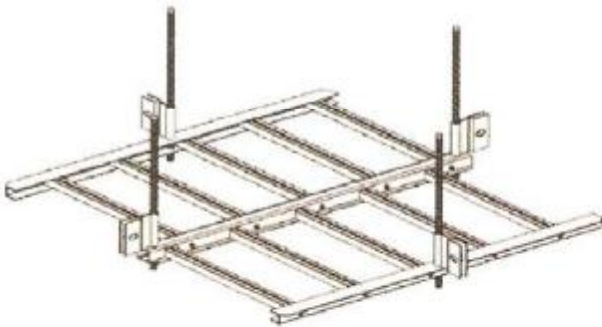

Figure 4.21C
HORIZONTAL HUB

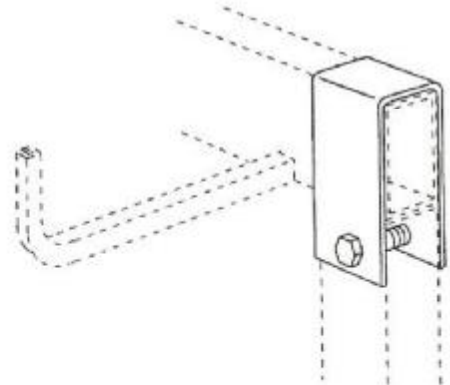

Figure 4.21D
VERTICAL TEE OR 90° CONNECTOR

4.4 FITTINGS INSTALLATION (See Section 4.4.3 for single rail and wire mesh cable trays)

4.4.1 Recommended Support Locations for Fittings
(unless otherwise recommended by the manufacturer)

Horizontal Elbow Support (See Figure 4.2.2)

Supports for horizontal cable tray fittings should be placed within 2 ft. (600 mm) of each fitting extremity, and as follows:

- a. 90° supports at the 45° point of arc.
- b. 60° supports at the 30° point of arc.
- c. 45° supports at the 22-1/2° point of arc (except for the 12 in. [300 mm] radii).
- d. 30° supports at the 15° point of arc (except for the 12 in. [300 mm] radii).

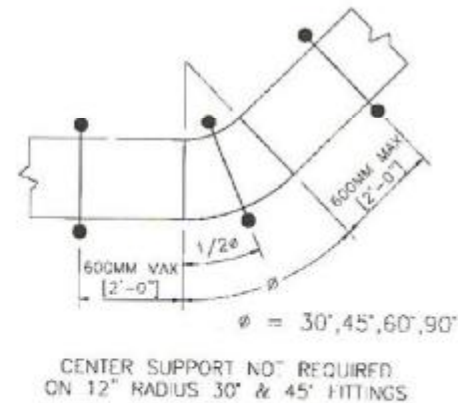

Figure 4.22
HORIZONTAL ELBOWS

Horizontal Tee Support (See Figure 4.23)

Place horizontal tee supports within 2 ft. (600 mm) of each of the three openings connected to other cable tray items for the 12 in. (300 mm) radius. On all other radii, at least one additional support should be placed under each side rail at the horizontal tee, preferably as shown.

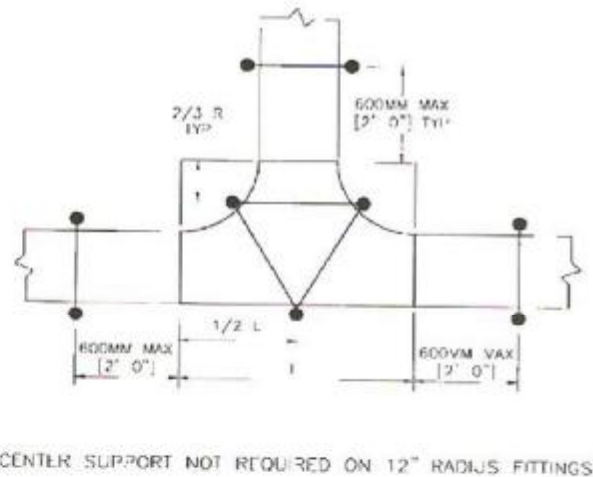

Figure 4.23
HORIZONTAL TEE

Horizontal Wye Support (See Figure 4.24)

Place horizontal wye supports within 2 ft. (600 mm) of each of the three openings connected to other cable tray items, and at 22-1/2° point of the arc adjacent to the side branch.

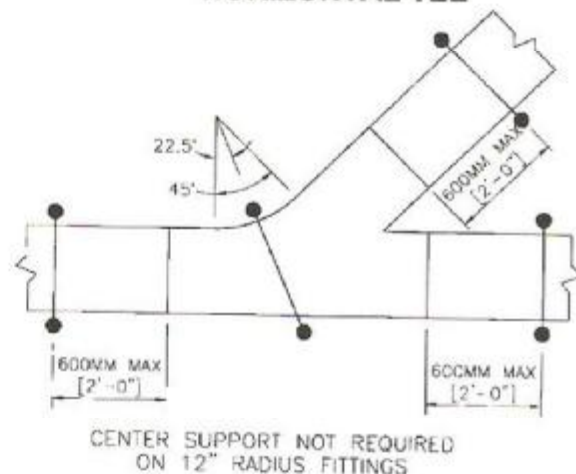
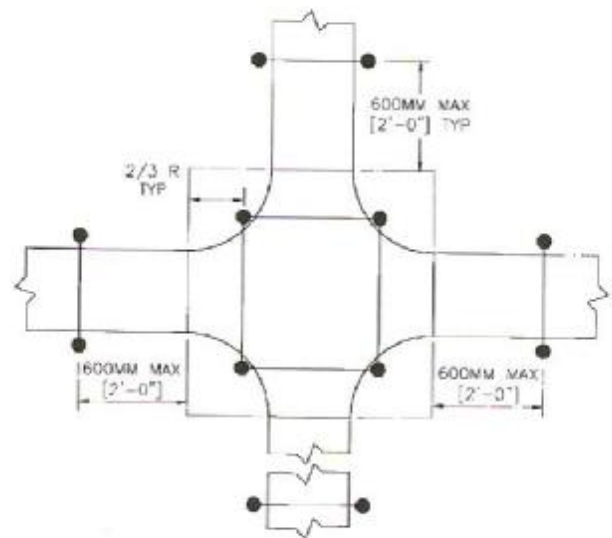

Figure 4.24
HORIZONTAL WYE

Horizontal Cross Support (See Figure 4.25)

Place horizontal cross support within 2 ft. (600 mm) of each of the four openings connected to other cable tray items for the 12 in. (300 mm) radius. On all other radii, at least one additional support should be placed under each side rail of the horizontal cross, preferably as shown.



CENTER SUPPORT NOT REQUIRED ON 12" RADIUS FITTINGS

**Figure 4.25
HORIZONTAL CROSS**

Reducer Support (See Figure 4.26)

Place reducer supports within 2 ft. (600 mm) of each fitting extremity.

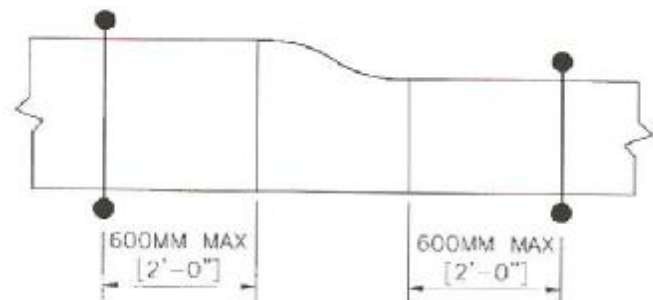

**Figure 4.26
REDUCER**

Vertical Cable Tray Elbows (See Figure 4.27)

Vertical cable tray elbows at the top of runs should be supported at each end. At the bottom of runs, they should be supported at the top of the elbow and within 2 ft. (600 mm) of the lower extremity of the elbows.

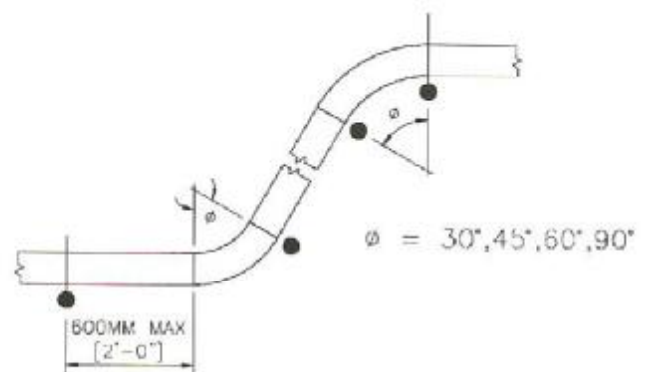

**Figure 4.27
VERTICAL ELBOWS
(Side View)**

Vertical Cable Tray Tees (See Figure 4.28)

Vertical cable tray tees should be supported within 2 ft. (600 mm) of each fitting extremity.

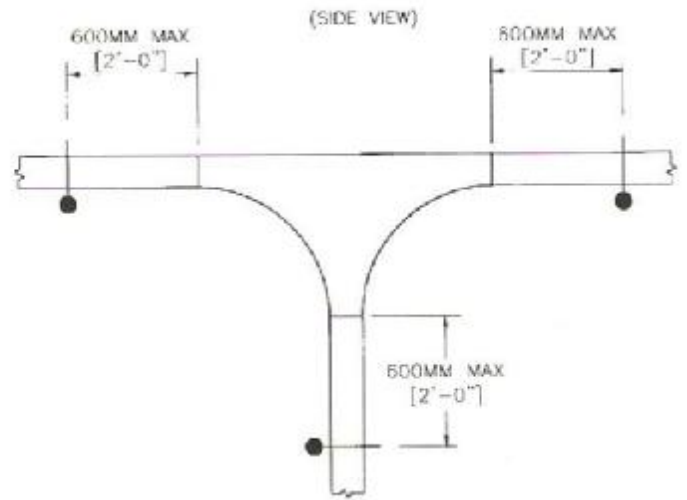

**Figure 4.28
VERTICAL TEE
(Side View)**

4.4.2 Cable Support Fitting (See Figures 4.29 and 4.30.)

These fittings are recommended for use at the top of long vertical runs of heavy cable to support the cables.

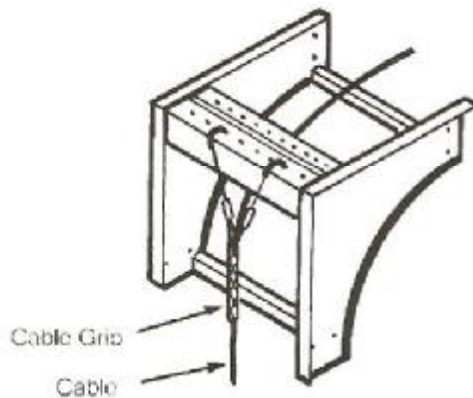

**Figure 4.29
VERTICAL CABLE SUPPORT**

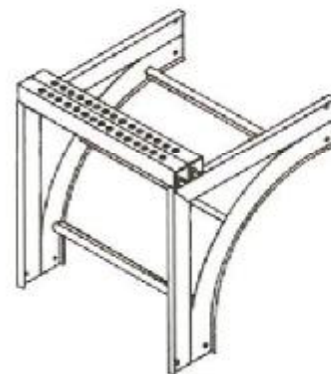

**Figure 4.30
VERTICAL CABLE SUPPORT**

4.4.3 Recommended Support Locations for Single Rail and Wire Mesh Cable Trays

Single rail and wire mesh cable trays have alternate support configurations. Consult manufacturer for details.

4.5 FIELD MODIFICATIONS

Eventually it will be necessary to field cut the cable tray because the length of the cable tray required will be less than standard length. If there are many cuts to be made in a given area, waste can be prevented by making a cut list, which can be used to calculate the most efficient use of the standard sections.

Cable tray field modifications shall be made by qualified personnel only.

4.5.1 Marking (See Figures 4.31 and 4.32)

Using a square that reaches across the width of the cable tray, gauge off the edge of one side rail and mark both flanges (Figure 4.31). Next, position the square as shown in (Figure 4.32) and mark the web of the rail. Marking can be done with a scribe, marking pen, or a pencil.

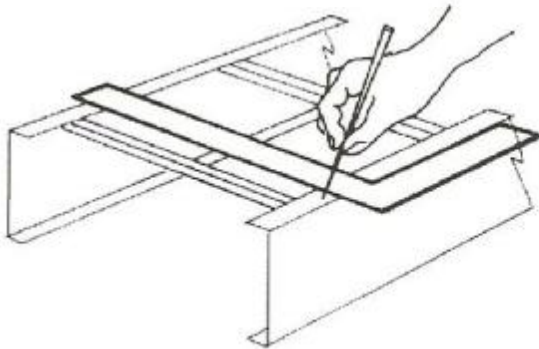

Figure 4.31
MARKING OF THE FLANGES

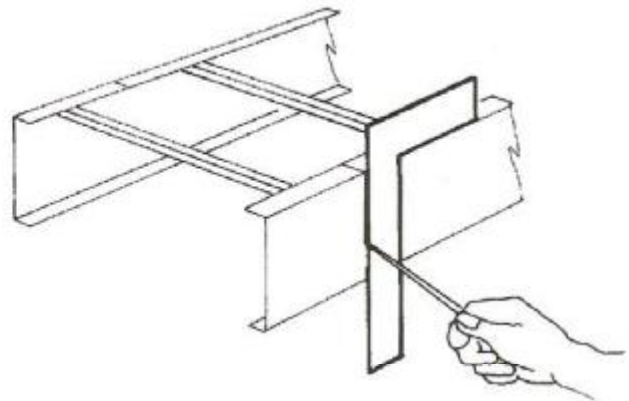

Figure 4.32
MARKING THE WEB OF THE RAIL

4.5.2 Cutting

The cut can be made using a hand held hack saw, carbide tipped circular saw, diamond dusted blades (fiberglass only), hand-held band saw, offset bolt cutters or high speed grinder (wire mesh only). It is important to get a square cut to ensure a good splice connection. Cable tray manufacturers offer jigs and other devices to aid in field cutting (Figure 4.33). After cutting, smooth the cut edges to remove any burrs. Fiberglass material should be cut with a carbide tipped circular saw or a diamond dusted blade.

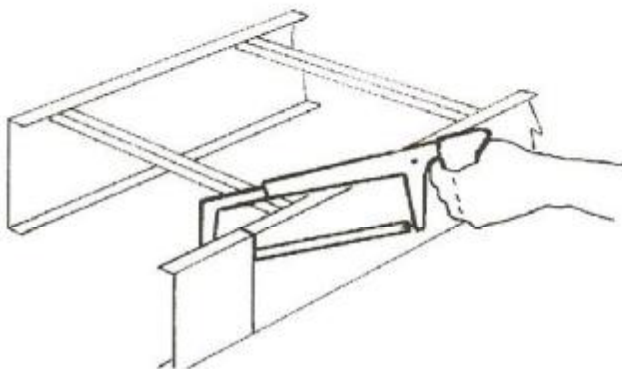

Figure 4.33A
CUTTING WITH HAND-HELD BAND SAW

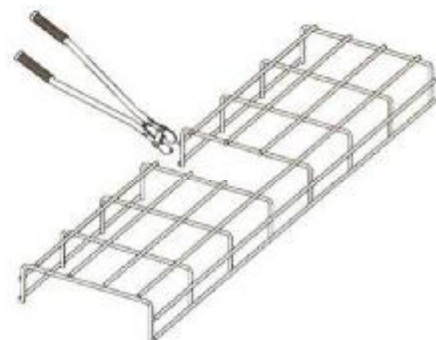

Figure 4.33B
CUTTING WITH BOLT CUTTERS

